

DO NOT SCALE

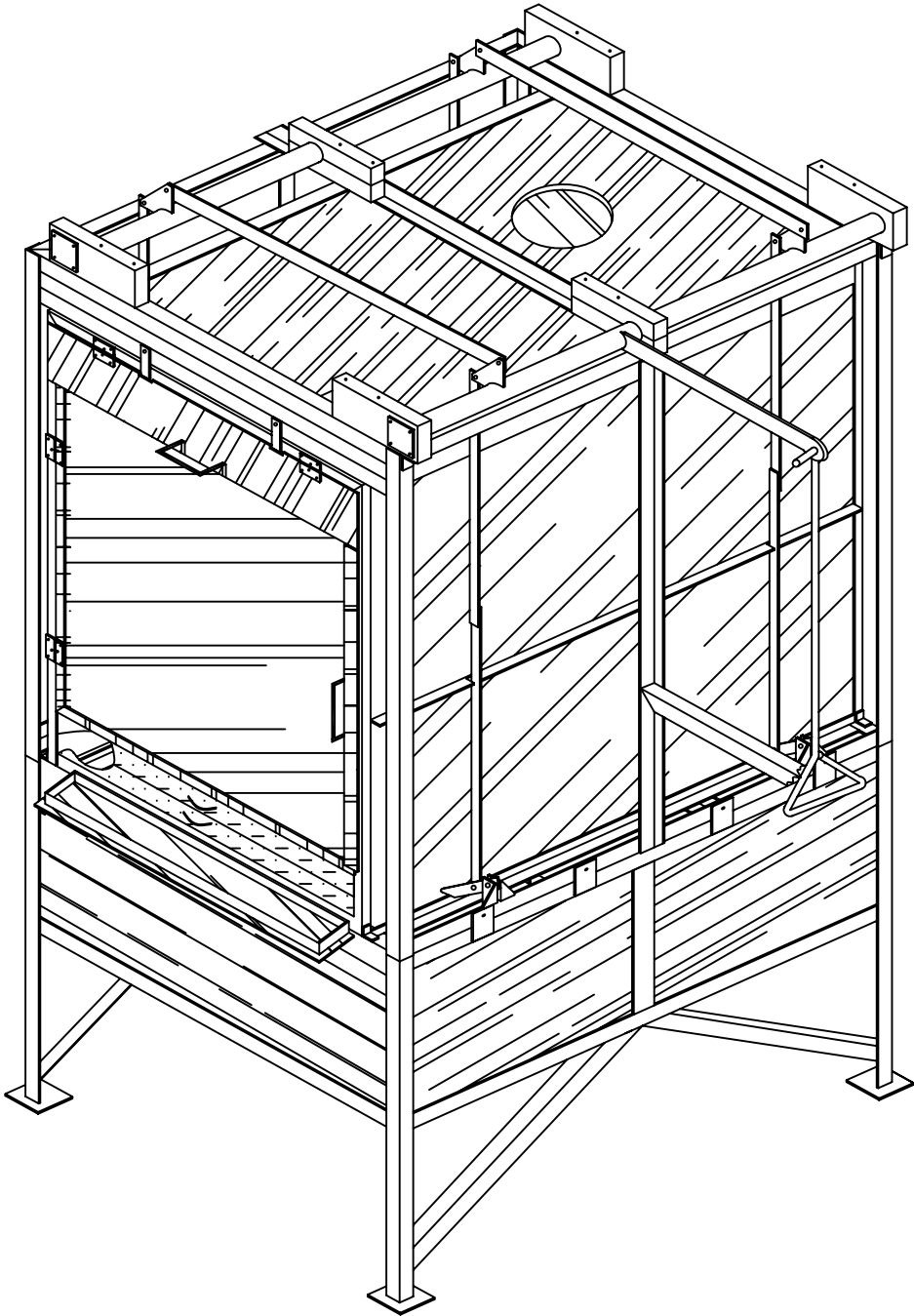

No.	Description	CHK	AP'D	DATE
REVISIONS				

Practical
Action

www.practicalaction.org
infoserv@practicalaction.org.uk

TITLE TRAY DRYER

DRAWN
A.R

TRACE
-

CHK
-

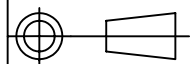

NOT TO
SCALE

DIMENSIONS IN MM

DRAWING No. TD101

DO NOT SCALE

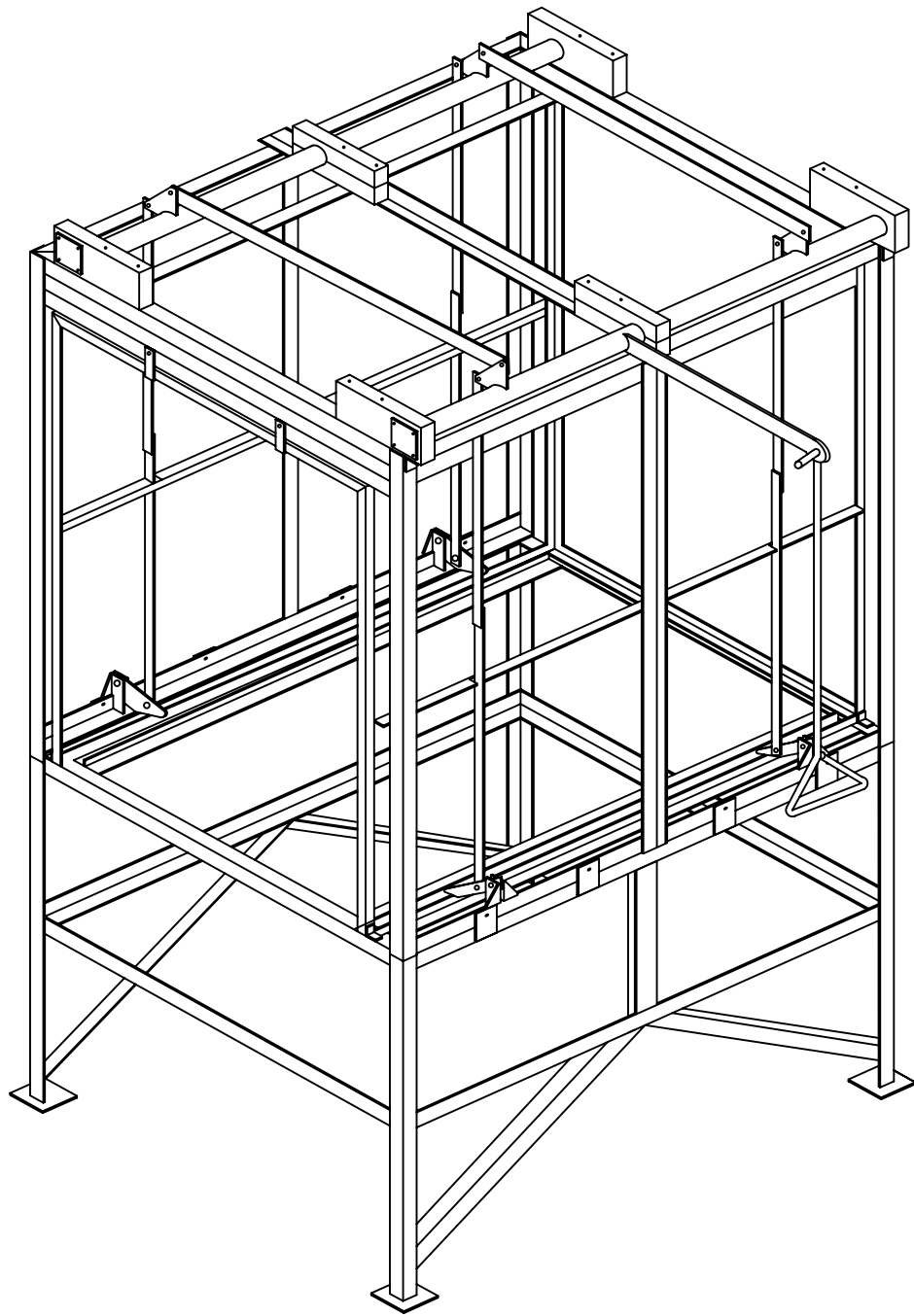

No.	Description	CHK	AP'D	DATE
REVISIONS				

Practical
Action

www.practicalaction.org
infoserv@practicalaction.org.uk

TITLE TRAY DRYER

DRAWN
A.R

TRACE
-

CHK
-

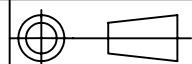

NOT TO
SCALE

DIMENSIONS IN MM

DRAWING No. TD102

DO NOT SCALE

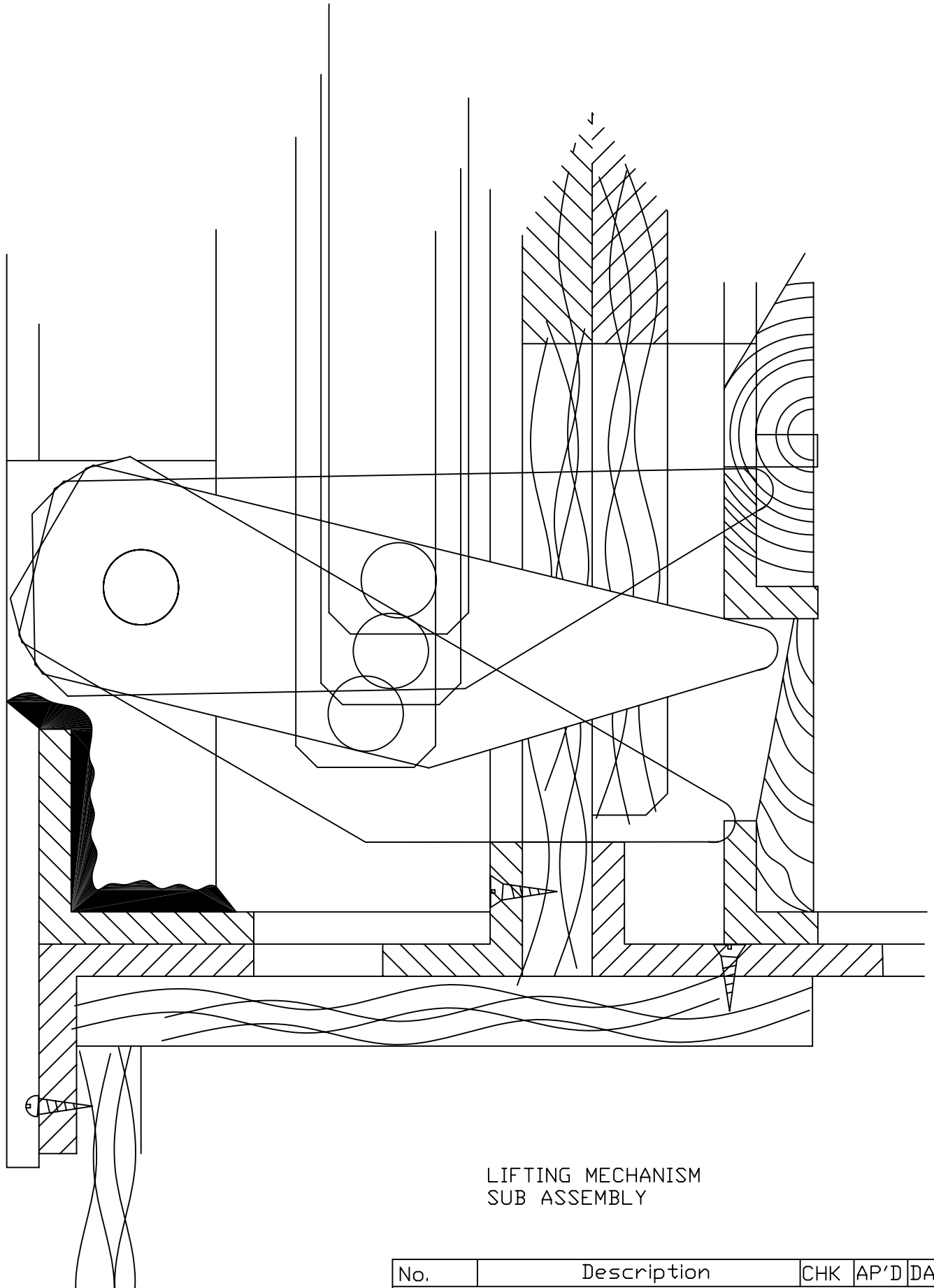

LIFTING MECHANISM
SUB ASSEMBLY

No.	Description	CHK	AP'D	DATE
REVISIONS				

Practical
Action

www.practicalaction.org
infoserv@practicalaction.org.uk

TITLE TRAY DRYER

DRAWN
A.R

TRACE
-

CHK
-

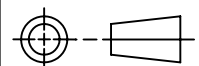

NOT TO
SCALE

DIMENSIONS IN MM

DRAWING No. TD103

DO NOT SCALE

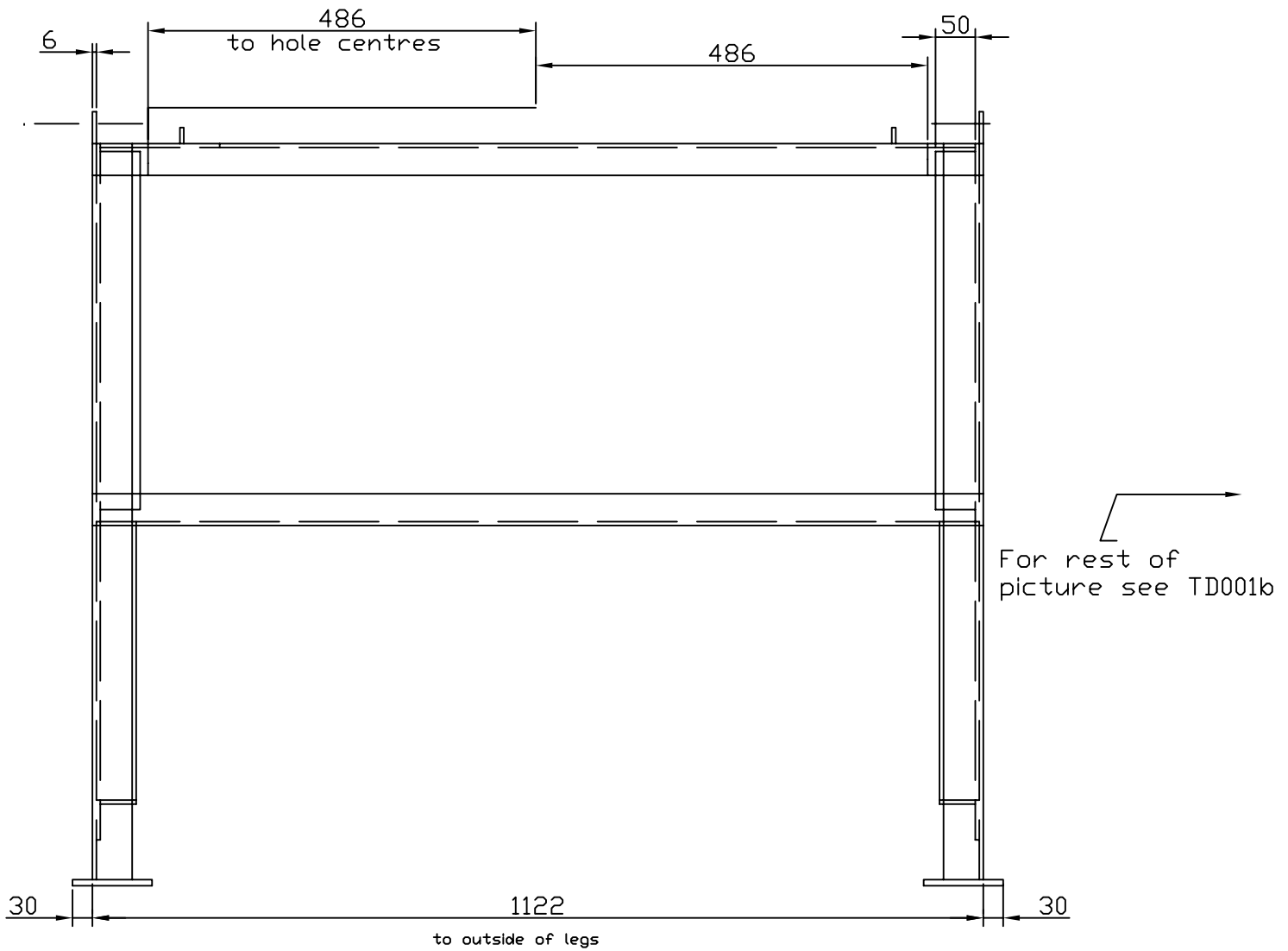

BASE - 1 OFF- MILD STEEL

(SEE DRAWING TD001-C FOR PLAN VIEW)

TD001	Side Elevation	-	-	-
No.	Description	CHK	AP'D	DATE
REVISIONS				

Practical
Action
www.practicalaction.org
infoserv@practicalaction.org.uk

TITLE TRAY DRYER

DRAWN
A.R

TRACE
-

CHK
-

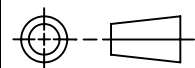

NOT TO
SCALE

DIMENSIONS IN MM

DRAWING No. TD001a

DO NOT SCALE

DIA 9.0
(8 OFF)

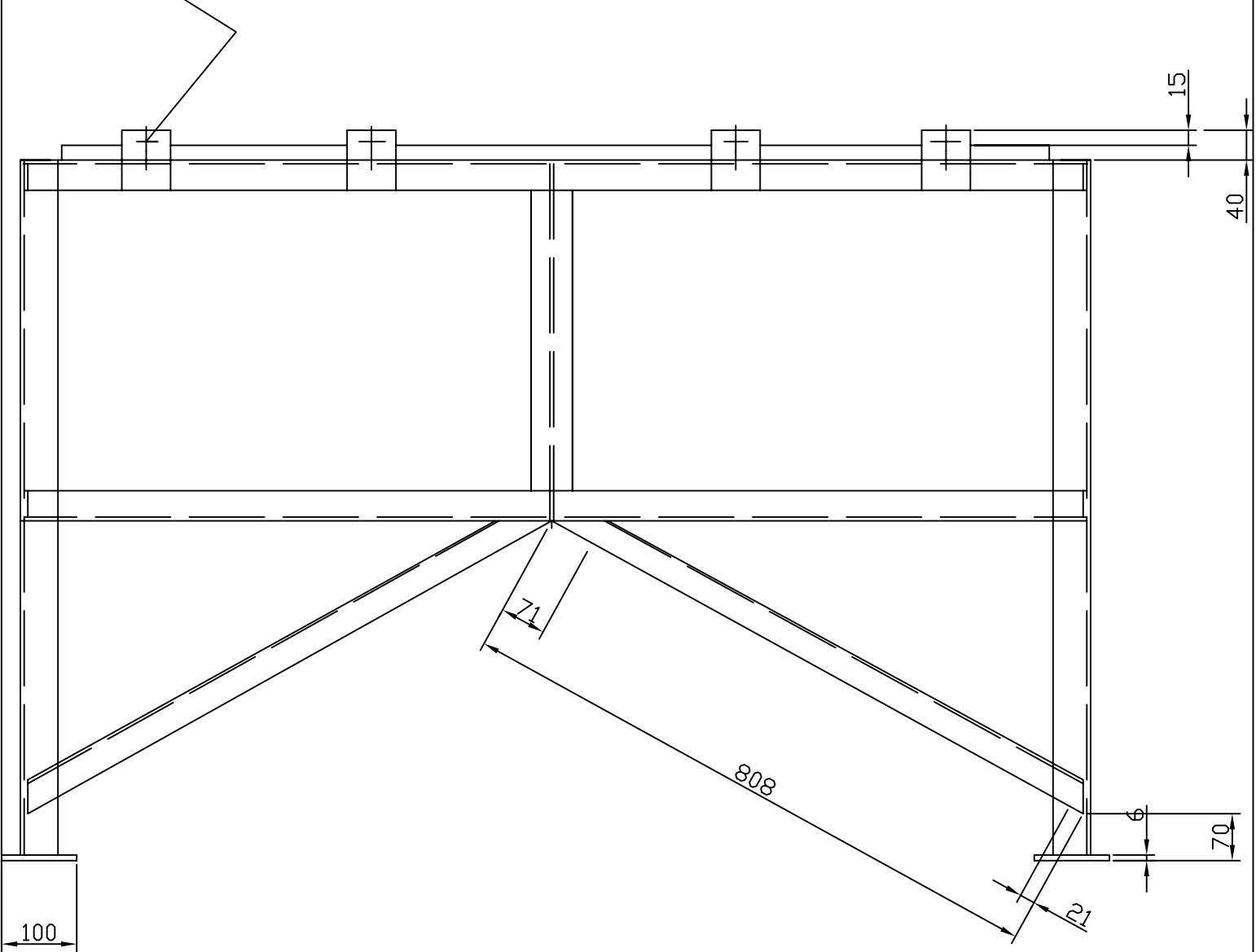

BASE - 1 OFF - MILD STEEL

<SEE DRAWING TD001-A FOR FRONT VIEW>

<SEE DRAWING TD001-C FOR PLAN VIEW>

TD001	Side Elevation	-	-	-
No.	Description	CHK	AP'D	DATE
REVISIONS				

Practical
Action

www.practicalaction.org
infoserv@practicalaction.org.uk

TITLE TRAY DRYER

DRAWN
A.R

TRACE
-

CHK
-

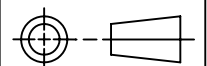

NOT TO
SCALE

DIMENSIONS IN MM

DRAWING No. TD001b

DO NOT SCALE

M8 (4 OFF)
DRILL AT LATER STAGE

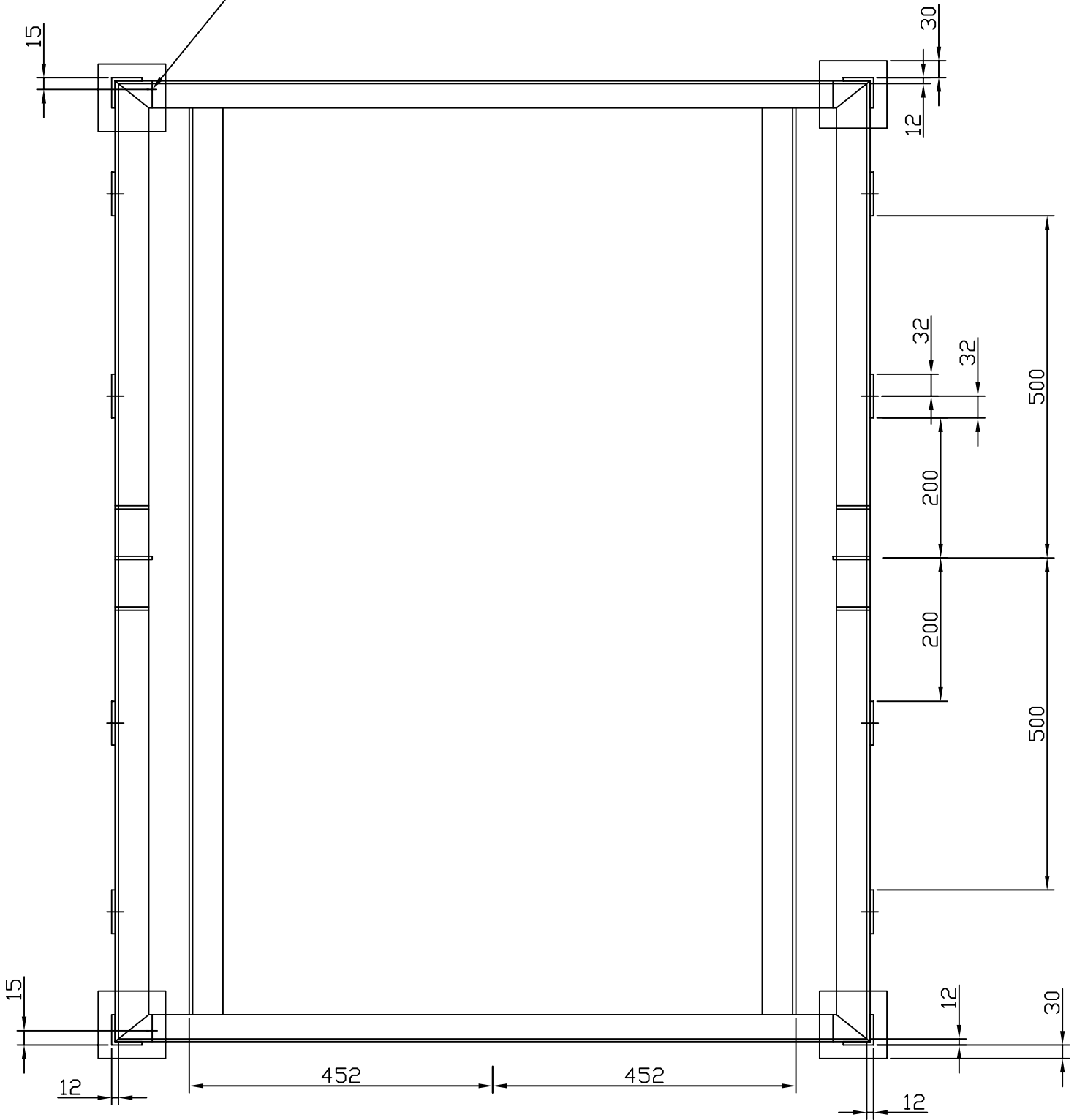

<SEE DRAWING TD001-A FOR FRONT VIEW>
<SEE DRAWING TD001-B FOR SIDE VIEW>

○ BASE - 1 OFF- MILD STEEL

No.	Description	CHK	AP'D	DATE
TD001	Side Elevation	-	-	-
REVISIONS				

Practical
Action

www.practicalaction.org
infoserv@practicalaction.org.uk

TITLE TRAY DRYER

DRAWN
A.R

TRACE
-

CHK
-

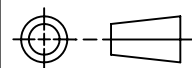

NOT TO
SCALE

DIMENSIONS IN MM

DRAWING No. TD001c

DO NOT SCALE

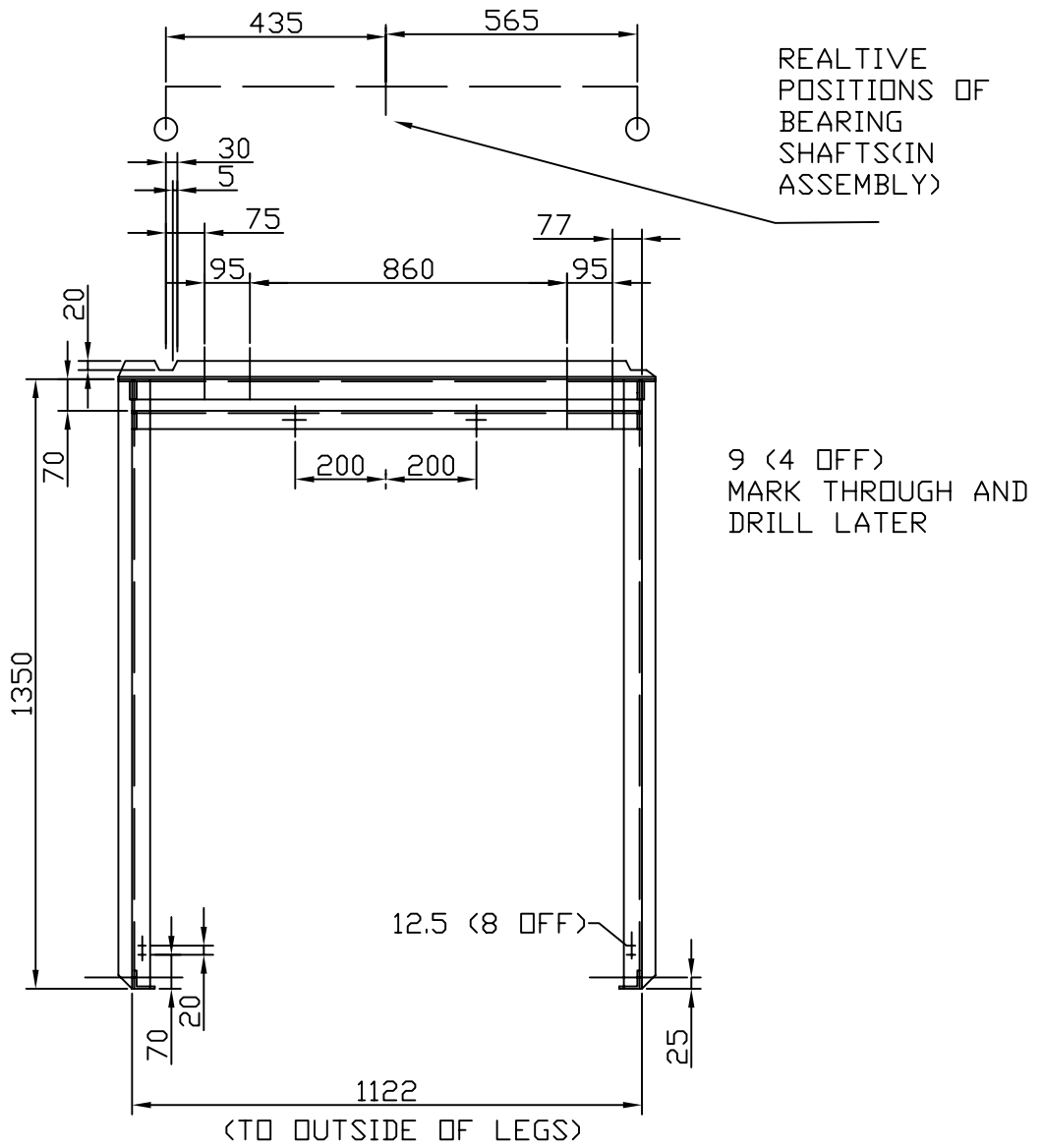

UPPER FRAME -
1 OFF - MILD
STEEL

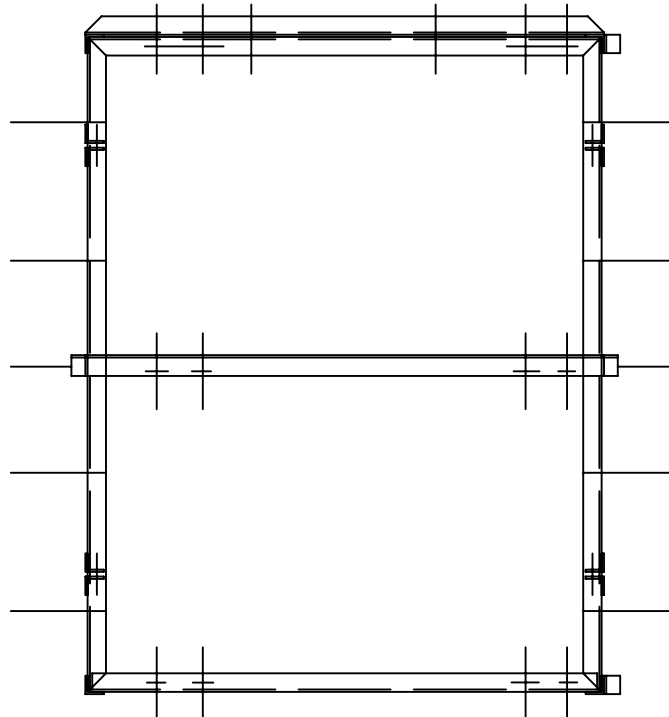

No.	Description	CHK	AP'D	DATE
REVISIONS				

Practical
Action

www.practicalaction.org
infoserv@practicalaction.org.uk

TITLE TRAY DRYER

DRAWN
A.R

TRACE
-

CHK
-

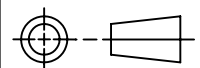

NOT TO
SCALE

DIMENSIONS IN MM

DRAWING No. TD002a

DO NOT SCALE

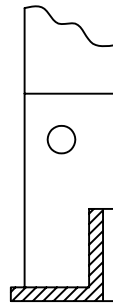
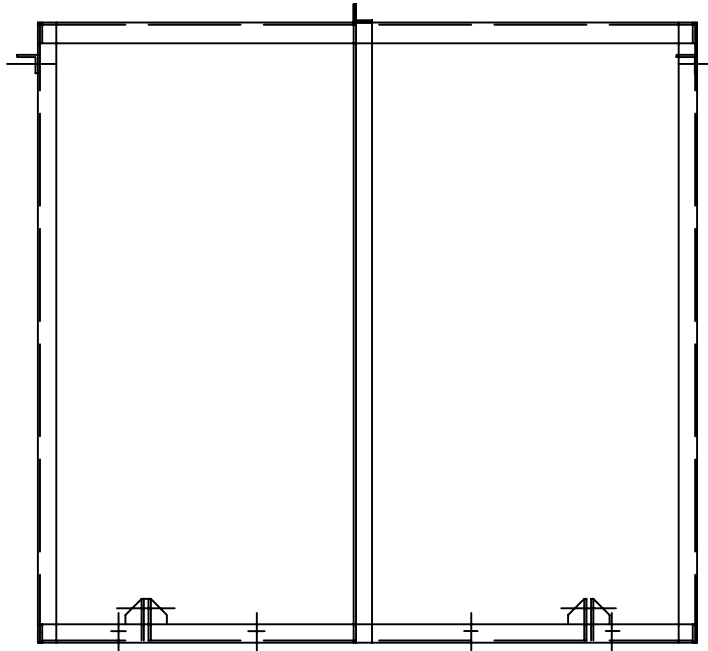

UPPER FRAME - 1 OFF - MILD STEEL

No.	Description	CHK	AP'D	DATE
		-	-	-
REVISIONS				

Practical
Action

www.practicalaction.org
infoserv@practicalaction.org.uk

TITLE TRAY DRYER

DRAWN
A.R

TRACE
-

CHK
-

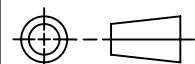

NOT TO
SCALE

DIMENSIONS IN MM

DRAWING No. TD002b

DO NOT SCALE

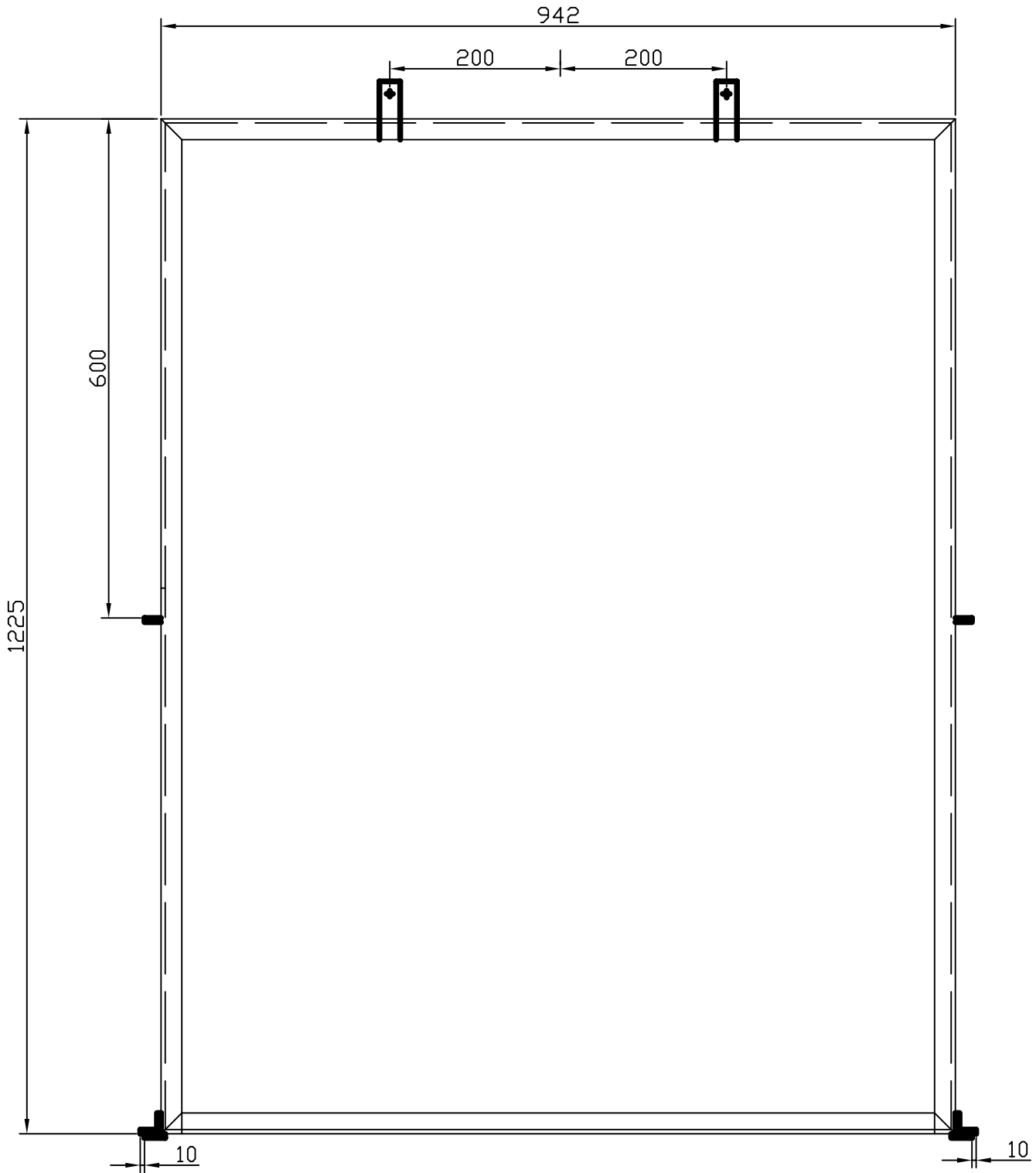

CABINET - 1 OFF- MILD STEEL

(SEE DRAWING TD003-B FOR PLAN VIEW)

No.	Description	CHK	AP'D	DATE
		-	-	-
REVISIONS				

Practical Action

www.practicalaction.org
infoserv@practicalaction.org.uk

TITLE TRAY DRYER

DRAWN A.R

TRACE -

CHK -

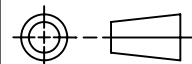

NOT TO SCALE

DIMENSIONS IN MM

DRAWING No. TD003a

DO NOT SCALE

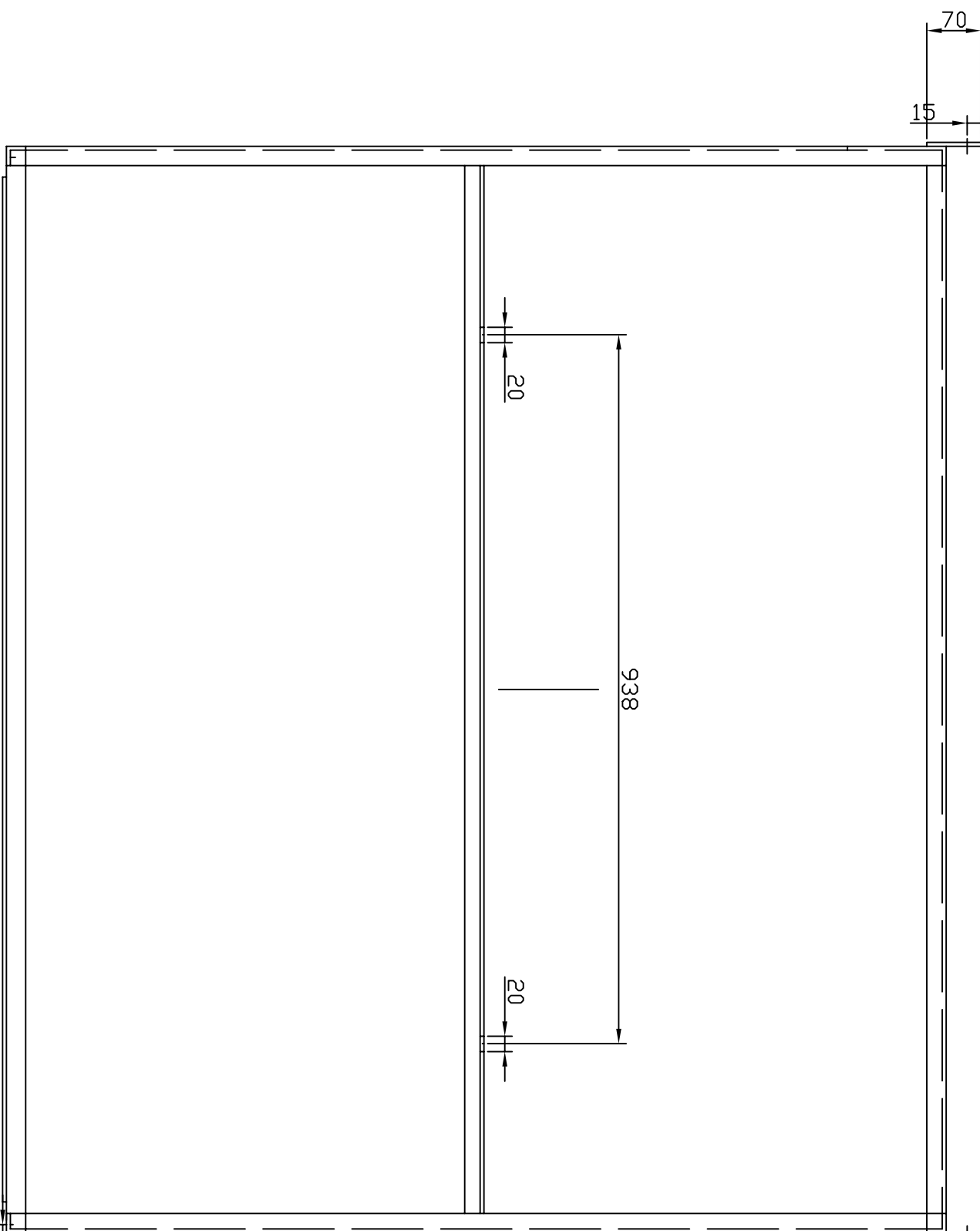

CABINET -
1 DFF -
MILD STEEL

(SEE DRAWING
TD003-A FOR ALT.
VIEW)

No. REVISIONS		CHK	AP'D	DATE	Practical Action www.practicalaction.org info@practicalaction.org		TITLE TRAY DRYER DIMENSIONS IN MM		DRAWN A.R	TRACE -	CHK -		NOT TO SCALE
Description													

DRAWING NO. TD003b

DO NOT SCALE

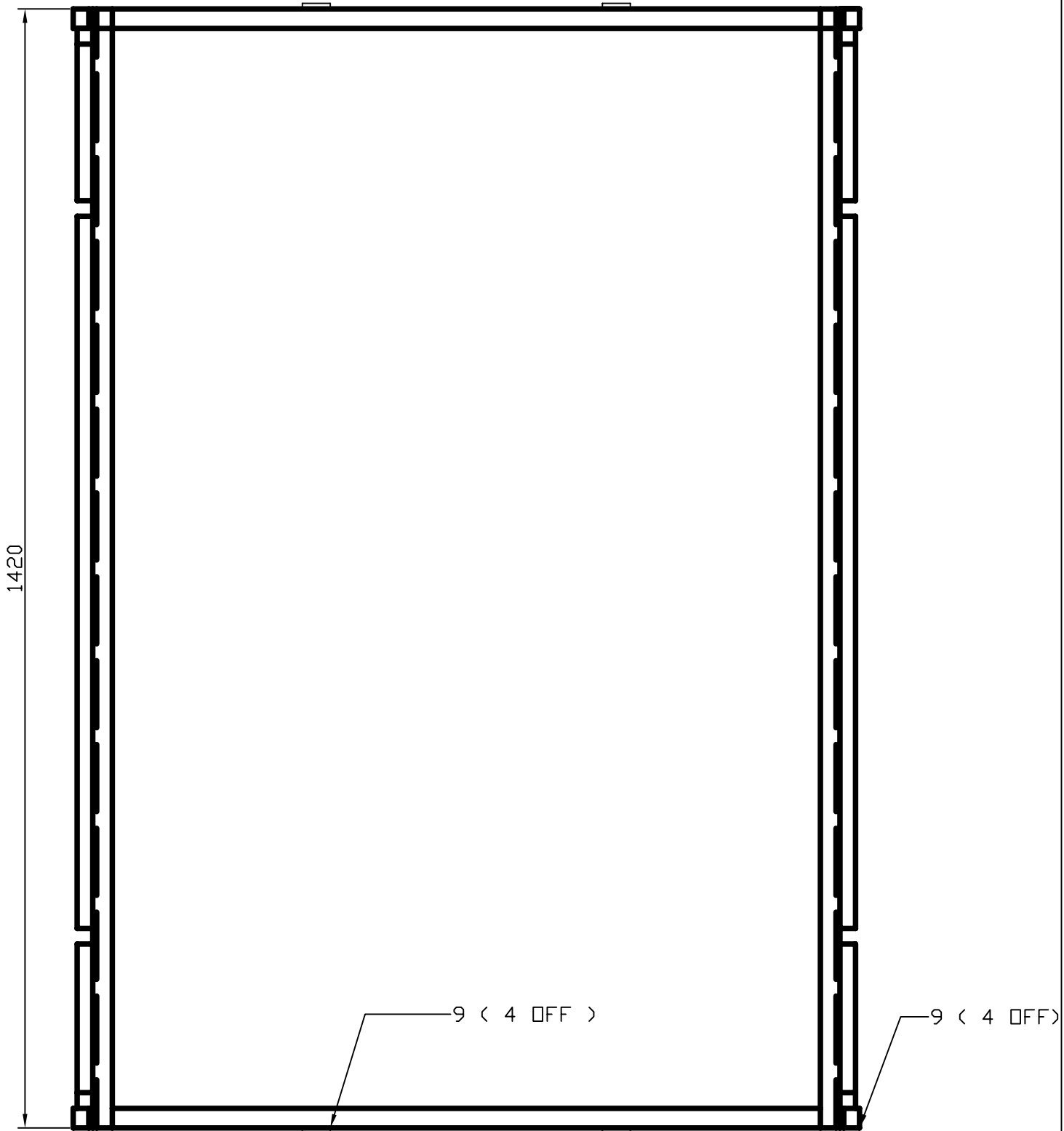

CABINET - 1 OFF - MILD STEEL

		-	-	-
No.	Description	CHK	AP'D	DATE
REVISIONS				

Practical
Action
www.practicalaction.org
infoserv@practicalaction.org.uk

TITLE TRAY DRYER

DRAWN A.R
TRACE -
CHK -

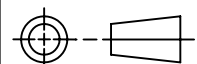

NOT TO SCALE

DIMENSIONS IN MM

DRAWING No. TD002c

DD NDT SCALE

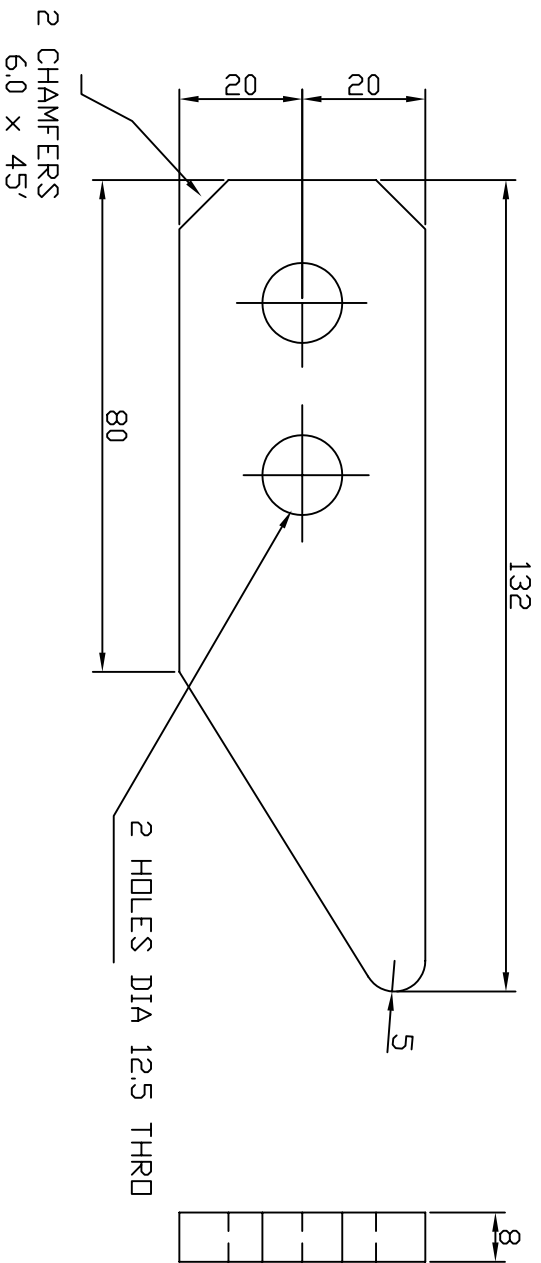

- MANUFACTURING NOTE
- For equal fingers:-
1. Cut the four finger out roughly and drill holes
 2. Bolt to gether and make profiles equal by grinding/ filing

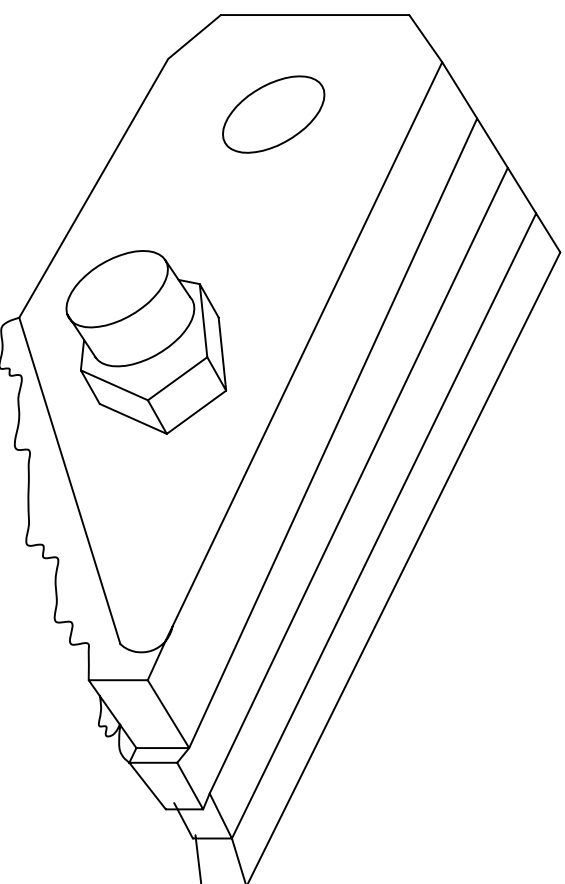
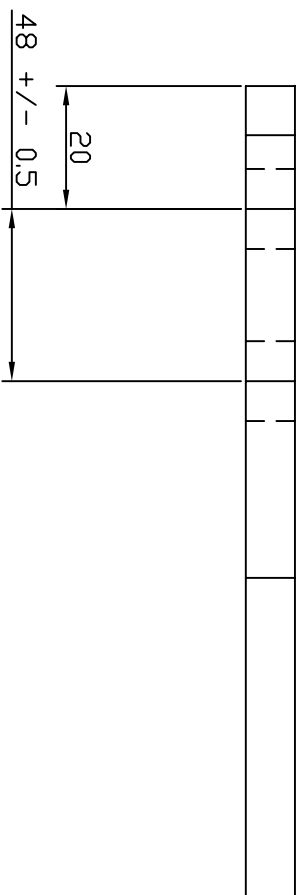

LIFTING FINGERS - OFF - MILD STEEL

No.	Description	CHK	AP'D	DATE
REVISIONS				

Practical Action www.practicalaction.org info@practicalaction.org.uk	TITLE	TRAY DRYER	DRAWN	TRACE	CHK	NDT TO SCALE
	DIMENSIONS IN MM		A,R	-	-	
			DRAWING NO.	TD004		

DO NOT SCALE

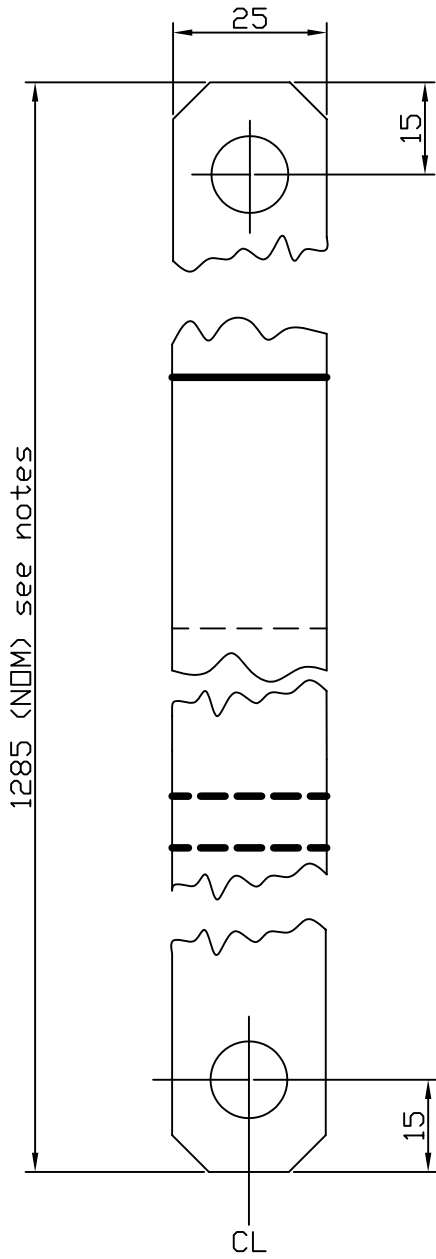

CAM FINGER TIE ROD

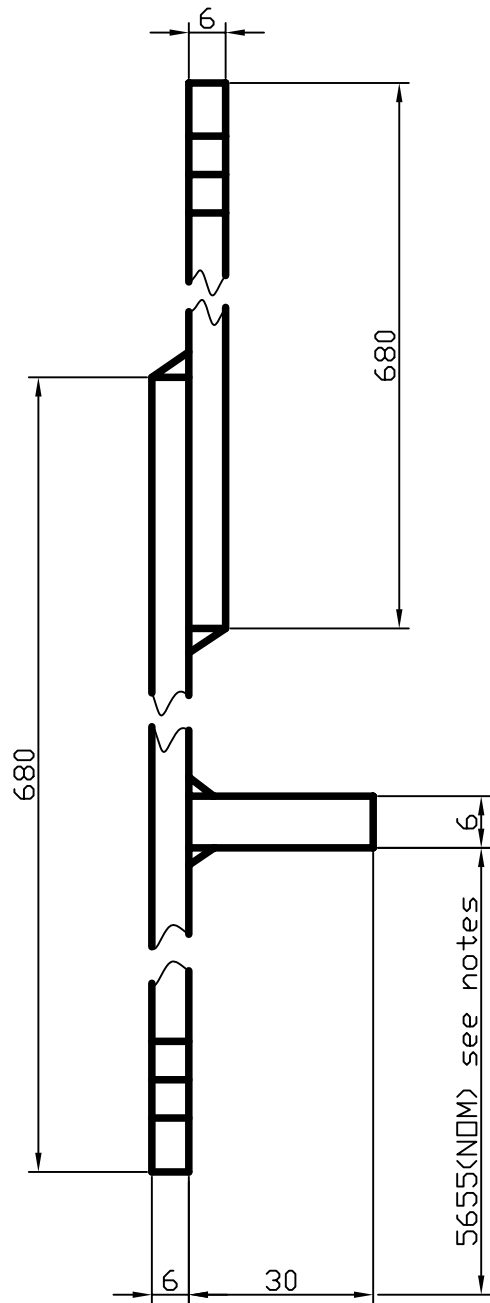

MANUFACTURING NOTE

Each cam-lever tie rod consists of 2 bars 680 long. A stop bar (30X25X6) is welded to one tie rod only. The rods are assembled in conjunction with the rest of the lifting mechanism and the main frame. This is described in the accompanying "construction notes".

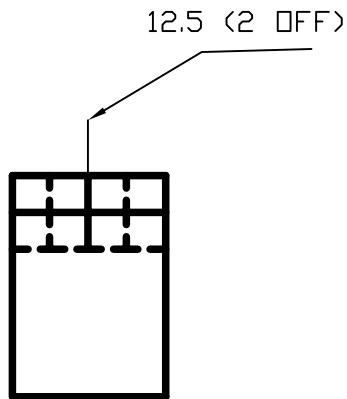

No.	Description	CHK	AP'D	DATE
		-	-	-
REVISIONS				

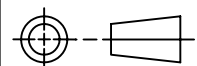

DO NOT SCALE

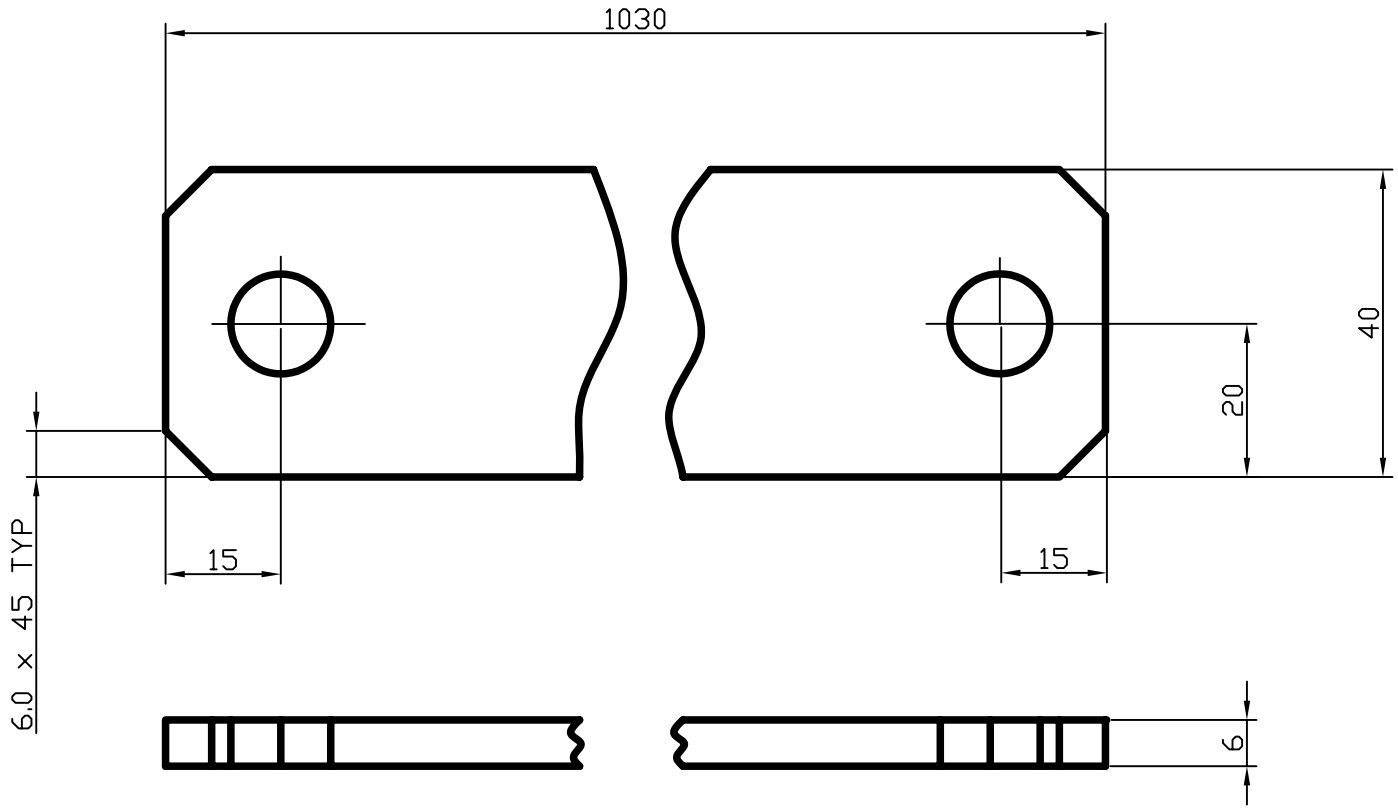

TOP CAM LINK - 2 OFF - MILD STEEL

Fabrication note

The distance between the holes is equal to the distance between centres of the lifting shafts when the latter are in position on top frame. (see general assembly-TD00)

No.	Description	CHK	AP'D	DATE

REVISIONS

Practical Action

www.practicalaction.org
infoserv@practicalaction.org.uk

TITLE TRAY DRYER

DRAWN A.R

TRACE -

CHK -

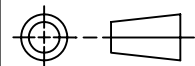

NOT TO SCALE

DIMENSIONS IN MM

DRAWING No. TD006

DO NOT SCALE

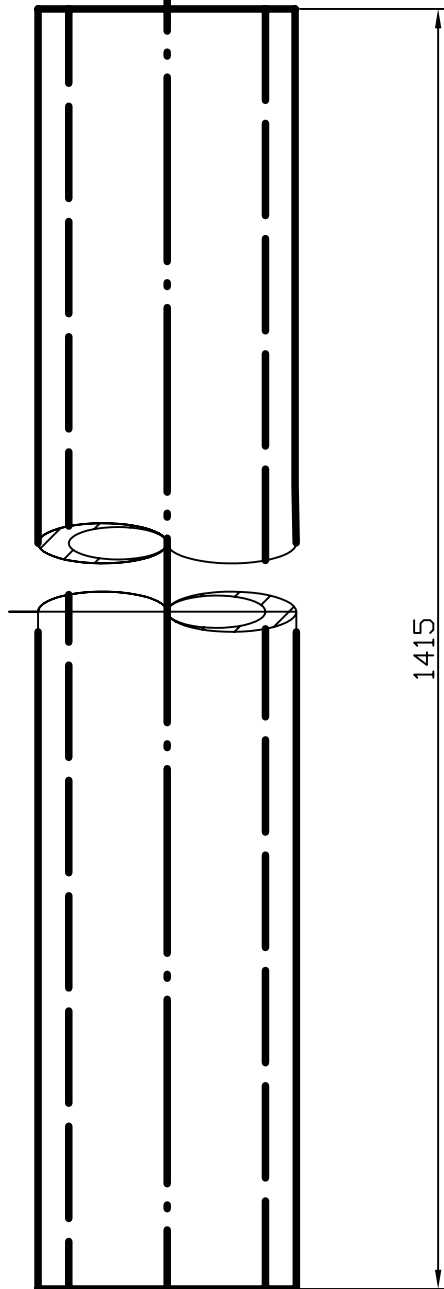
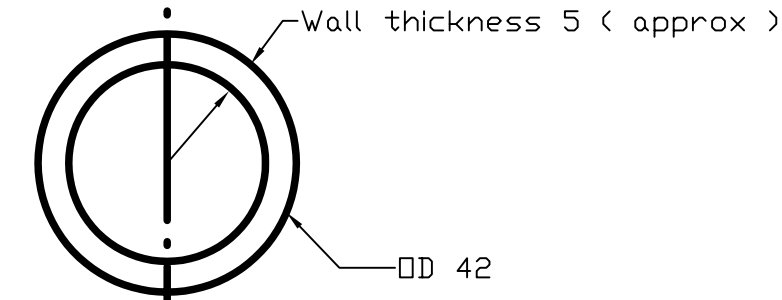

General Note

All the components in drawings TD001 - 013 (inclusive) are drawn in the orientation they are in, in the general assembly TD101

BEARING SHAFT
- MILD STEEL

No.	Description	CHK	AP'D	DATE
		-	-	-
REVISIONS				

Practical
Action

www.practicalaction.org
infoserv@practicalaction.org.uk

TITLE TRAY DRYER

DRAWN
A.R

TRACE
-

CHK
-

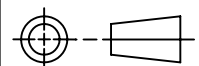

NOT TO
SCALE

DIMENSIONS IN MM

DRAWING No. TD007

DD NDT SCALE

600

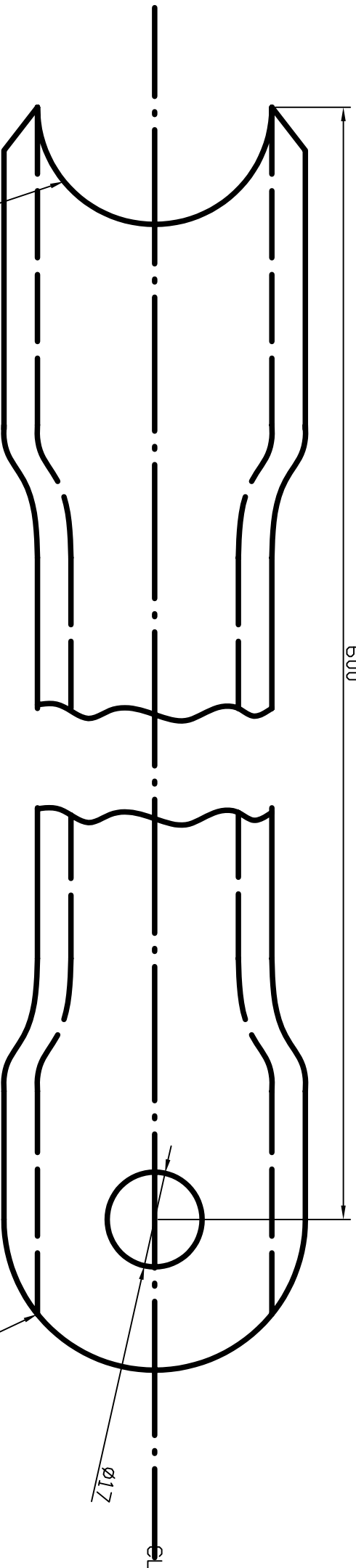

R21 TO SUITE DD DF
BEARING SHAFT

ROUGHLY ROUNDED

ø17

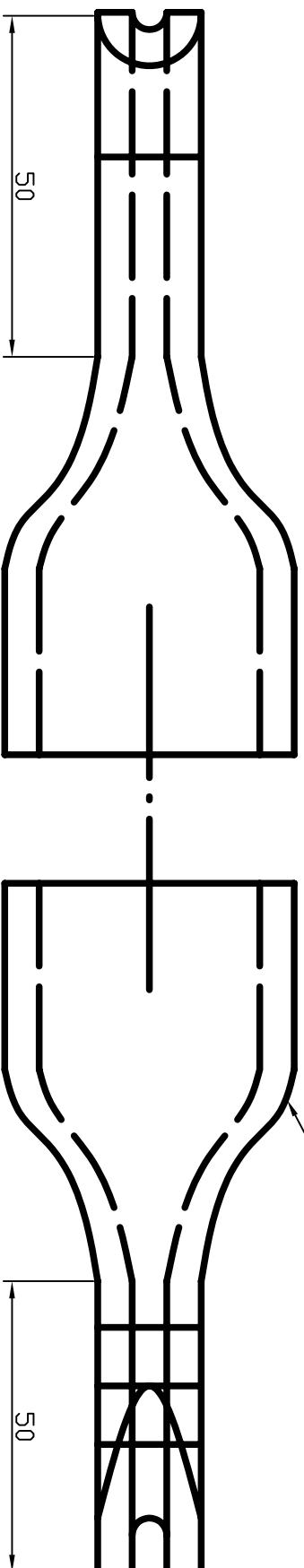

DD 42 WITH 5mm WALL

50

50

Notes
The lever is made from DD 42 mm tubing - 630mm long. Ends are flattened for a distance of 50.

TOLERANCES
UNLESS OTHERWISE
STATED +/- 0.25

OPERATING LEVER - MILD
STEEL - DFF

Practical Action www.practicalaction.org info@practicalaction.org.uk		TITLE SEMI-CONTINUOUS TRAY DRIER		DRAWN A.R		TRACE -		CHK -		NDT TO SCALE	
DIMENSIONS IN MM		DRAWING No. TD008									
No.	Description	CHK	AP'D	DATE							
REVISIONS											

DD NDT SCALE

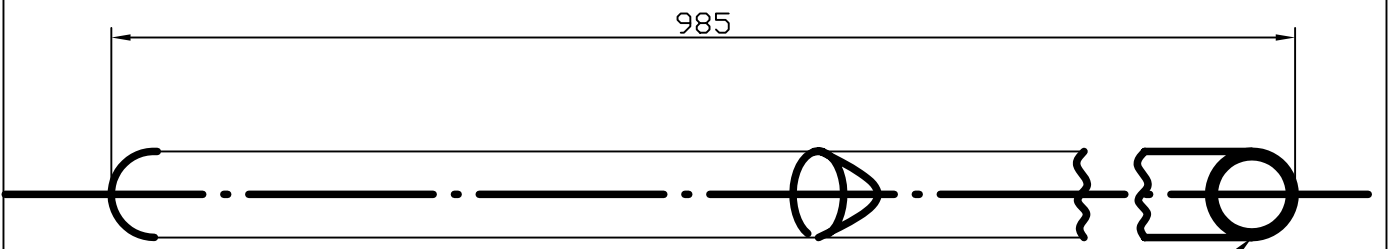
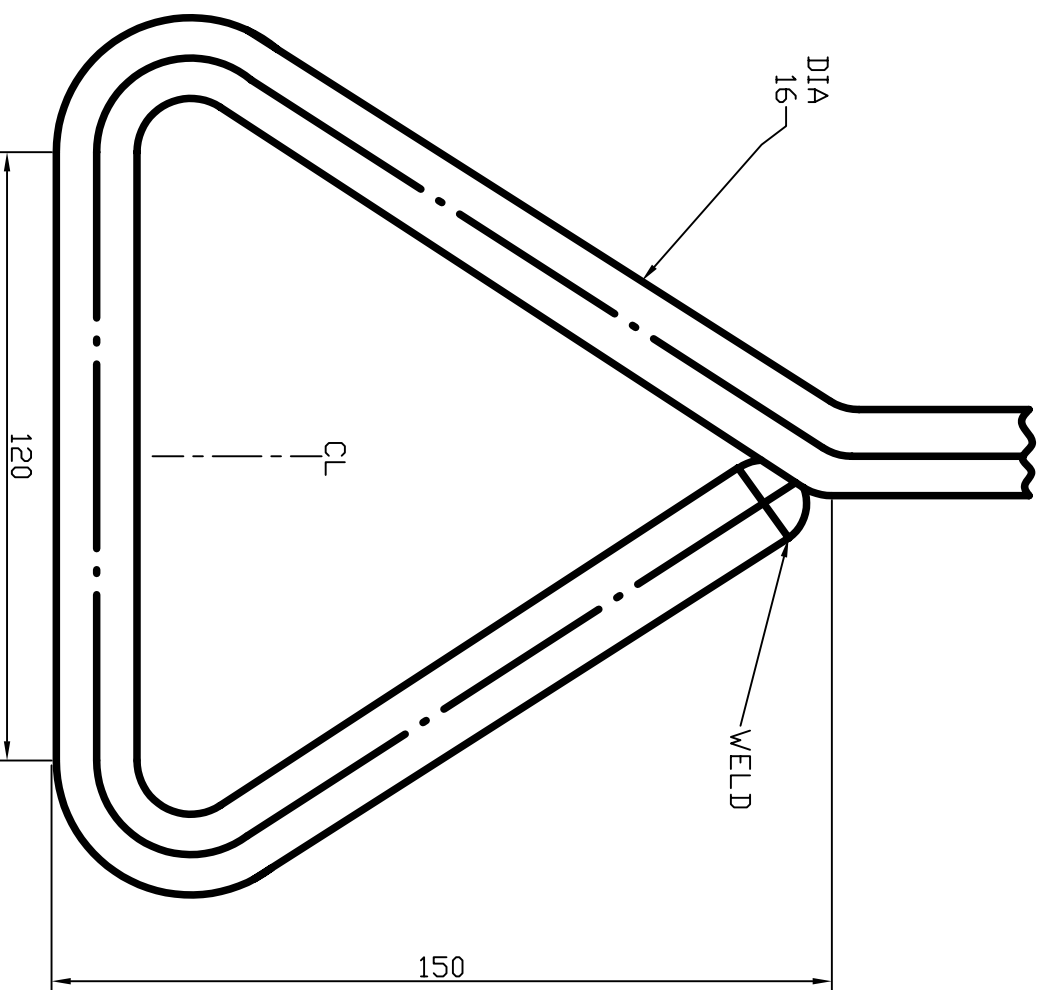
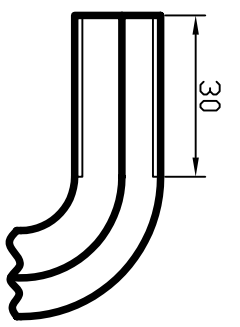

NOTE

The operating lever extension is made from 16mm bar bent and threaded as shown. Bar length approx 1500. Bend radii are not specified as they are not important

OPERATING LEVER HANDLE
EXTENSION BAR - MILD
STEEL - DFF

TOLERANCES
UNLESS OTHERWISE
STATED +/- 0.25

No.					
REVISIONS	Description	CHK	AP'D	DATE	

Practical Action
www.practicalaction.org
info@practicalaction.org.uk

TITLE SEMI-CONTINUOUS
TRAY DRIER
DIMENSIONS IN MM

DRAWN	TRACE	CHK		NDT TO
A/R	-	-		SCALE
DRAWING No. TD009				

DD NOT SCALE

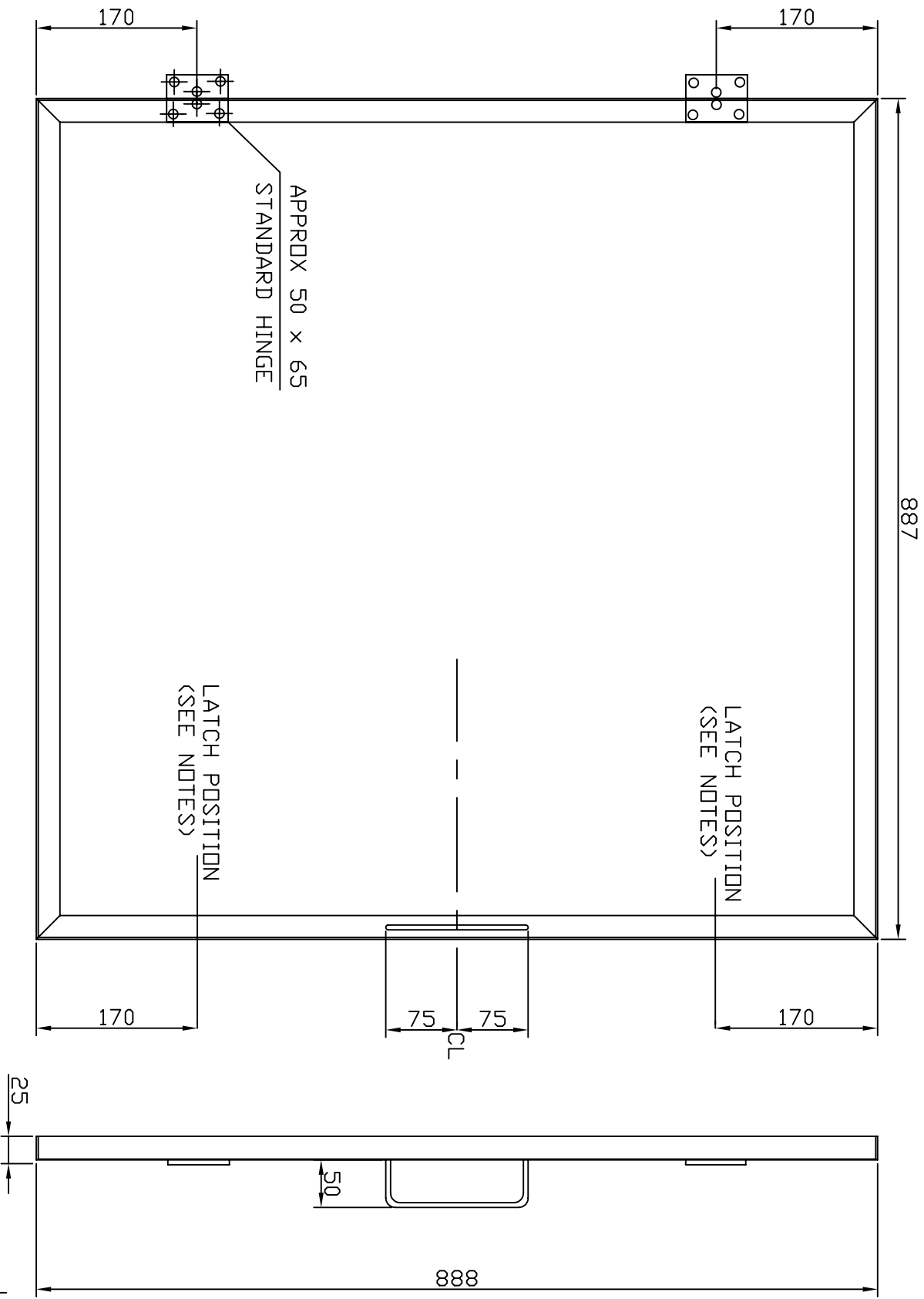

Notes
 The cabinet doors are made from a single length of angle iron (shown in drawing) or 4 separate lengths.
 The doors are slightly undersize, with plywood overlaps for draught proofing (see TD102)

Latches are mounted on top of the draught strips in the positions indicated in the drawings.
 Hinges are track welded to drying cabinet or base (see GA)

LARGE DOOR - MILD STEEL - 1 OFF

Practical Action www.practicalaction.org info@practicalaction.org.uk		TITLE SEMI-CONTINUOUS TRAY DRIER		DRAWN A.R	TRACE -	CHK -	NOT TO SCALE	
DIMENSIONS IN MM		DRAWING No. TD012						
No. REVISIONS	Description	CHK	AP'D	DATE				

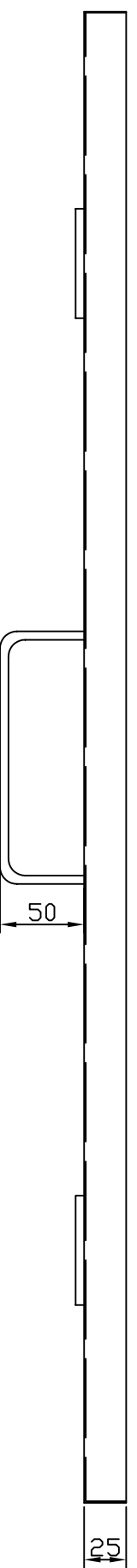
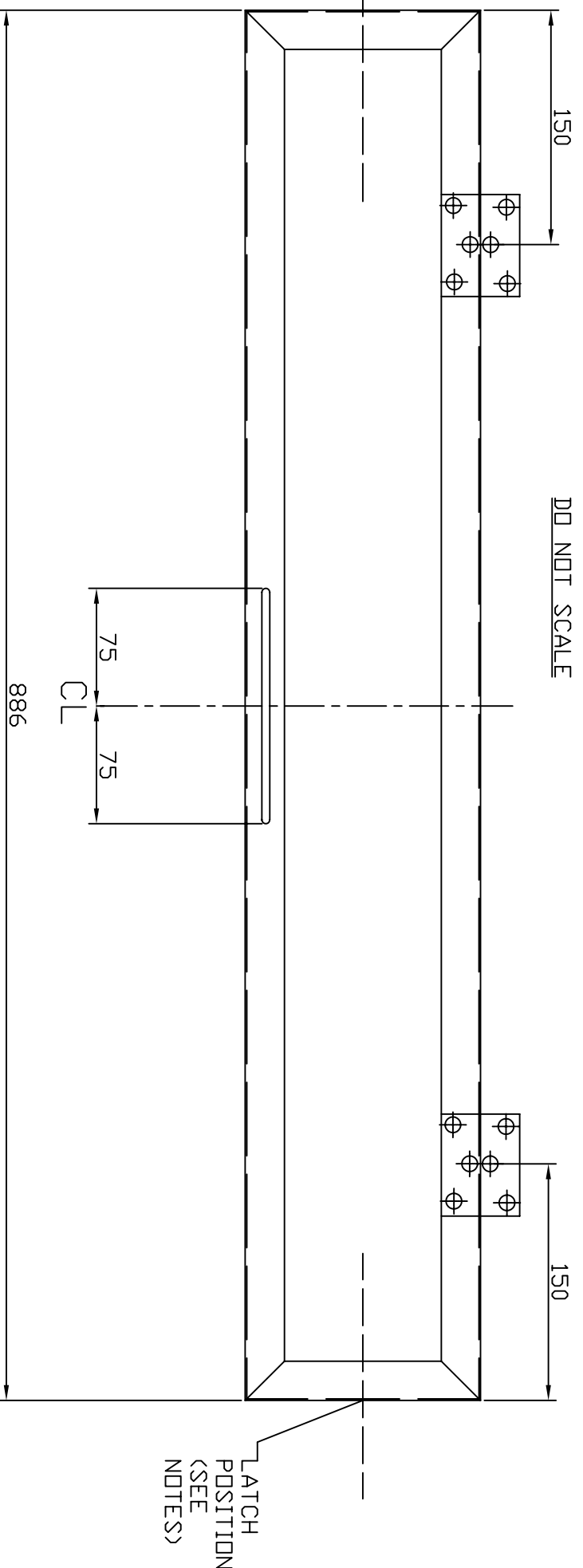

NOTE
REFER TO NOTE ON TD01

SMALL DOOR - MILD STEEL - 2 OFF

No. REVISIONS		Description		CHK	AP'D	DATE	Practical Action www.practicalaction.org info@practicalaction.org	TITLE SEMI-CONTINUOUS TRAY DRIER DIMENSIONS IN MM	DRAWN A.R TRACE - CHK -		NDT TO SCALE

DD NDT SCALE

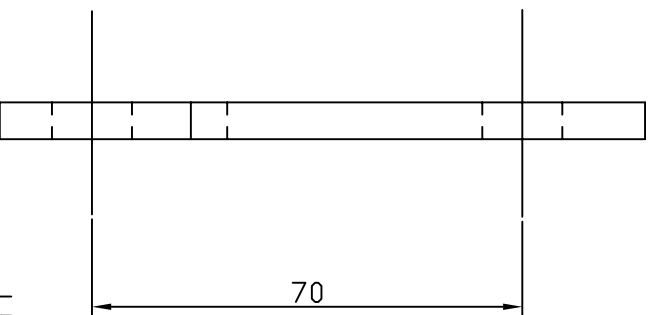
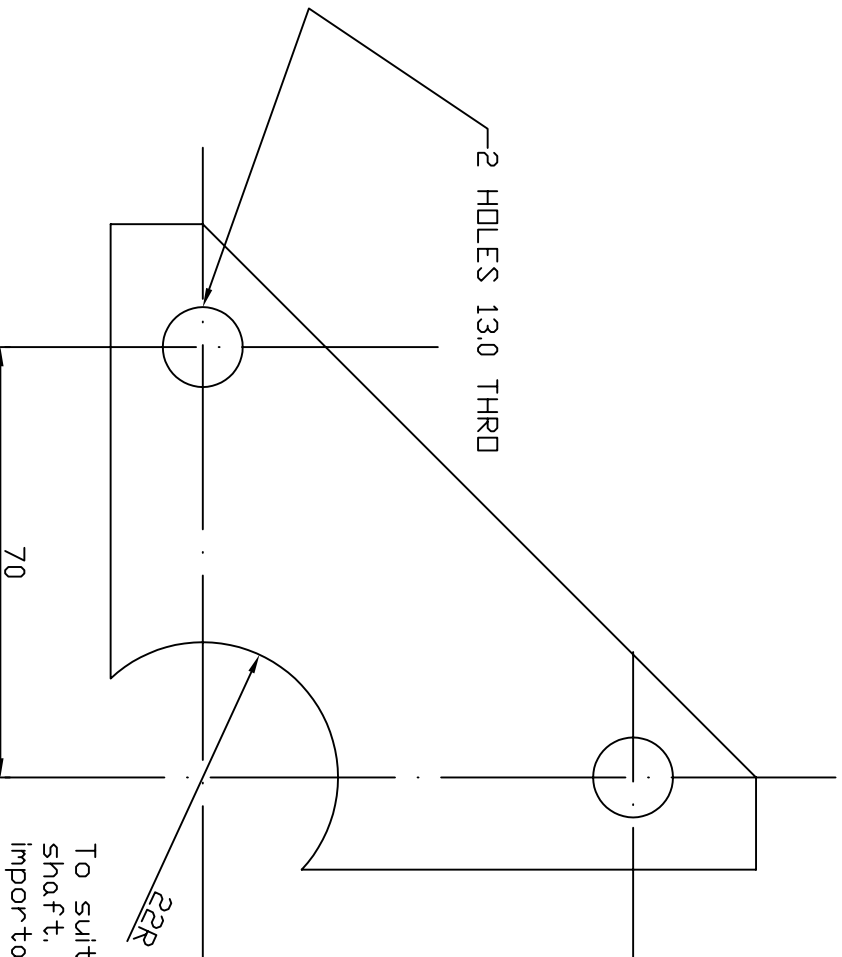

LEVER PLATE
LIFTING
MECHANISM -
MILD STEEL

Notes

The cams translates movement of the operat. handle to the 4 lifting fingers. 4 cams are required and approx 90 x90 6 thick steel plate is used per cam. The only critical dimensions are hole radii and their relative positions.

Where a drill is used to create the 22R half hole it is suggested that a full hole is drilled in a large piece of plate, thus allowing both halves of the hole to be used.

Practical Action www.practicalaction.org info@practicalaction.org.uk		TITLE TRAY DRYER		DRAWN A.R		TRACE -		CHK -		NDT TO SCALE	
Description		DIMENSIONS IN MM		DRAWING No. TD014							
No. REVISIONS	CHK	AP'D	DATE								

DD NDT SCALE

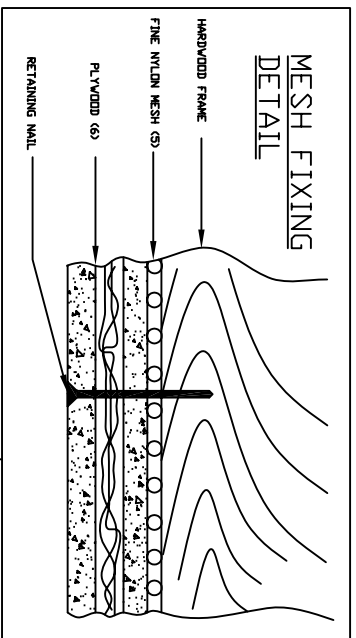

SIDE ELEVATION

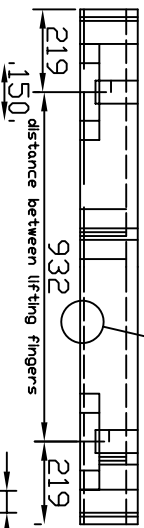

END ELEVATION

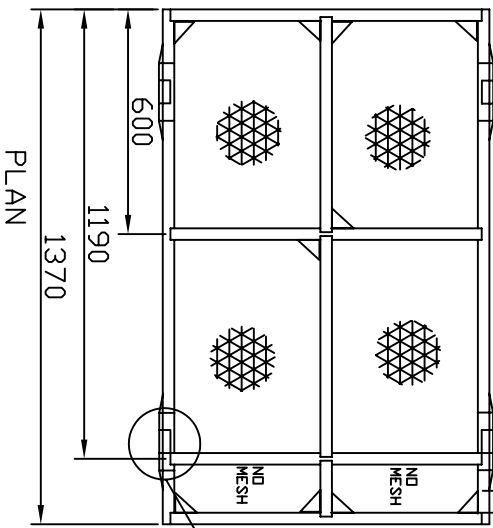
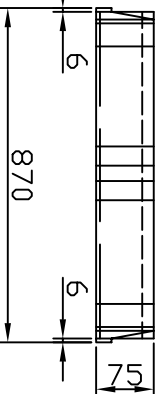

PLAN

NOTE

The only critical dimensions are overall tray length, width and height and positioning of lifting point reinforcements and cutaways

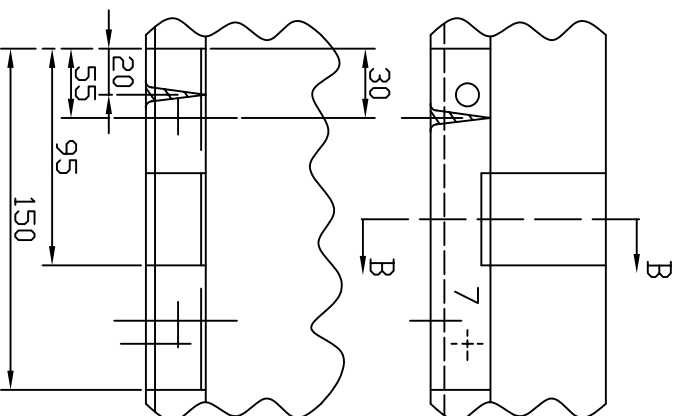

SECTION - BB

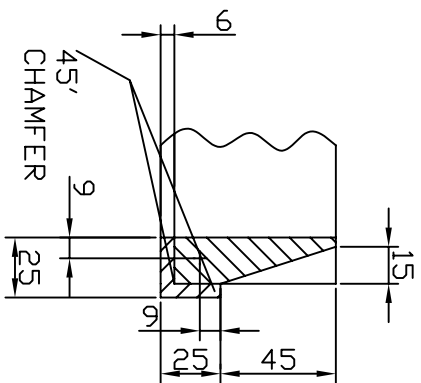

DETAIL OF CORNER REINFORCEMENT AND CUTAWAY AT LIFTING POINTS

TRAY - WOOD - 15 OFF

Parts list and Materials

- Frame ends and sides hardwood of 69x19mm section.
1. Ends - 2 lengths of 832
 2. Sides - 2 of 1370
 3. Dividers - 2 of 832, 1 of 576, 1 of 579, 1 of 159 of 50x19mm
 4. Corner strengtheners - 8 of 70x70x69, 2 of 70x70x59
 5. Netting - 1 of 1200x860 fine nylon mesh
 6. Netting retainers - 6mm Exterior ply 19mm width total length of 6922
 7. Lifting point reinforcement - 4 of 25x25 angle Iron x150 long
 8. Ramp - 8 of 5x60 wedge
- Nails and woodscrews as required
1 dryer requires 15 trays

No.	Description	CHK	AP'D	DATE	Practical Action www.practicalaction.org info@practicalaction.org.uk	TITLE	TRAY DRYER	DRAWN	TRACE	CHK	NDT TO SCALE
								A.R	-	-	
REVISIONS						DIMENSIONS IN MM		DRAWING NO. TD015			

DO NOT SCALE

SIDE GUIDES
- WOOD -
4 DFF

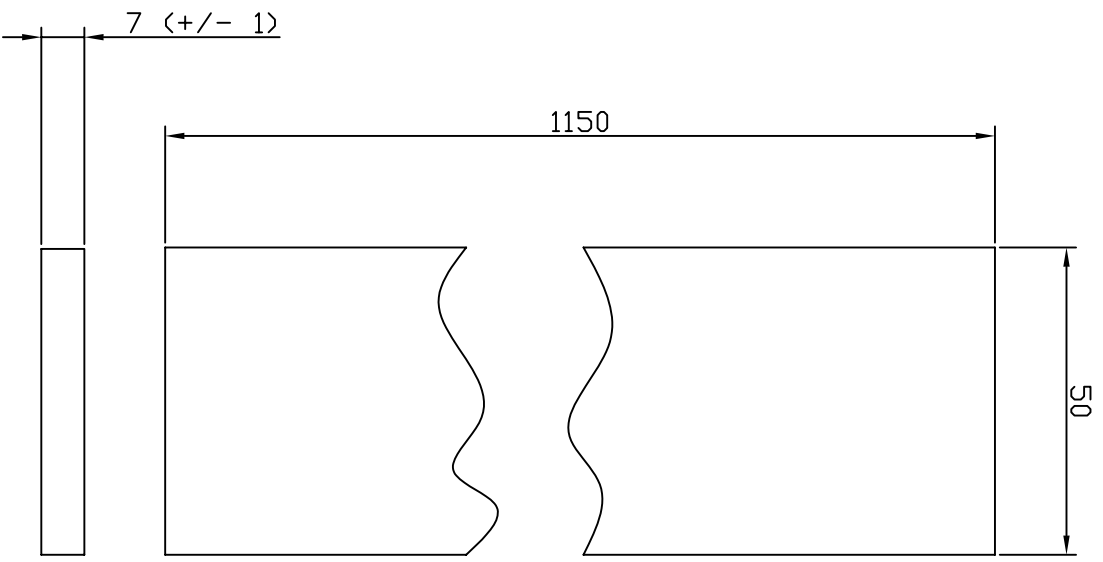
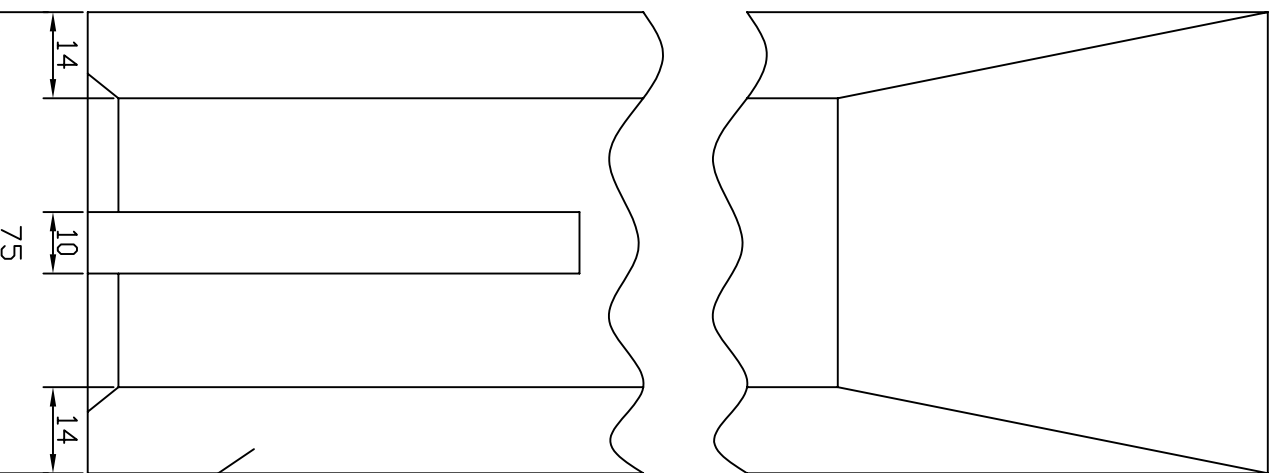
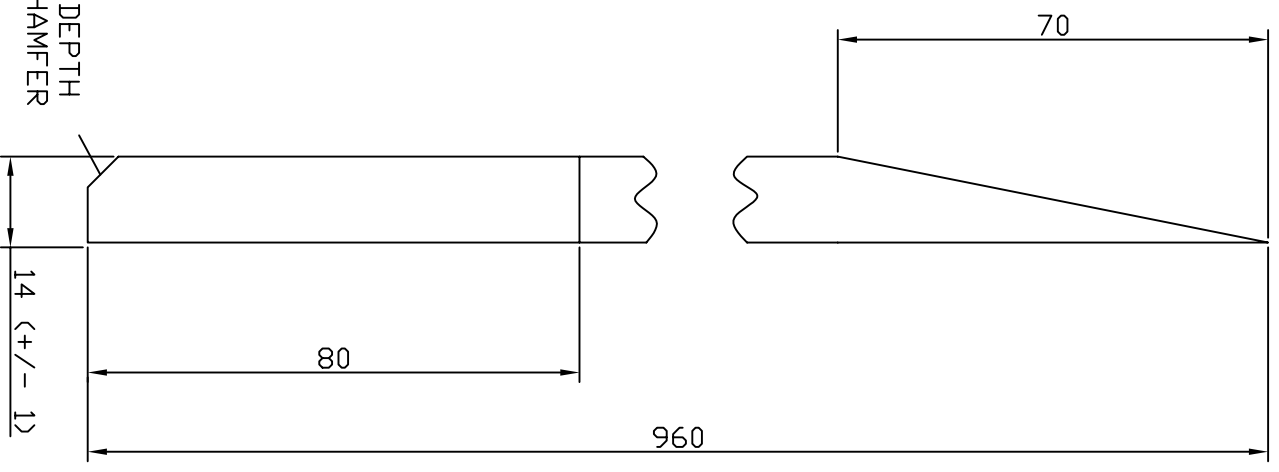

No.	Description	CHK	AP'D	DATE
REVISIONS				

Practical Action www.practicalaction.org info@practicalaction.org.uk		TITLE TRAY DRYER			DRAWN	TRACE	CHK	NDT TO SCALE
DIMENSIONS IN MM					A/R	-	-	
					DRAWING No. TD016			

DO NOT SCALE

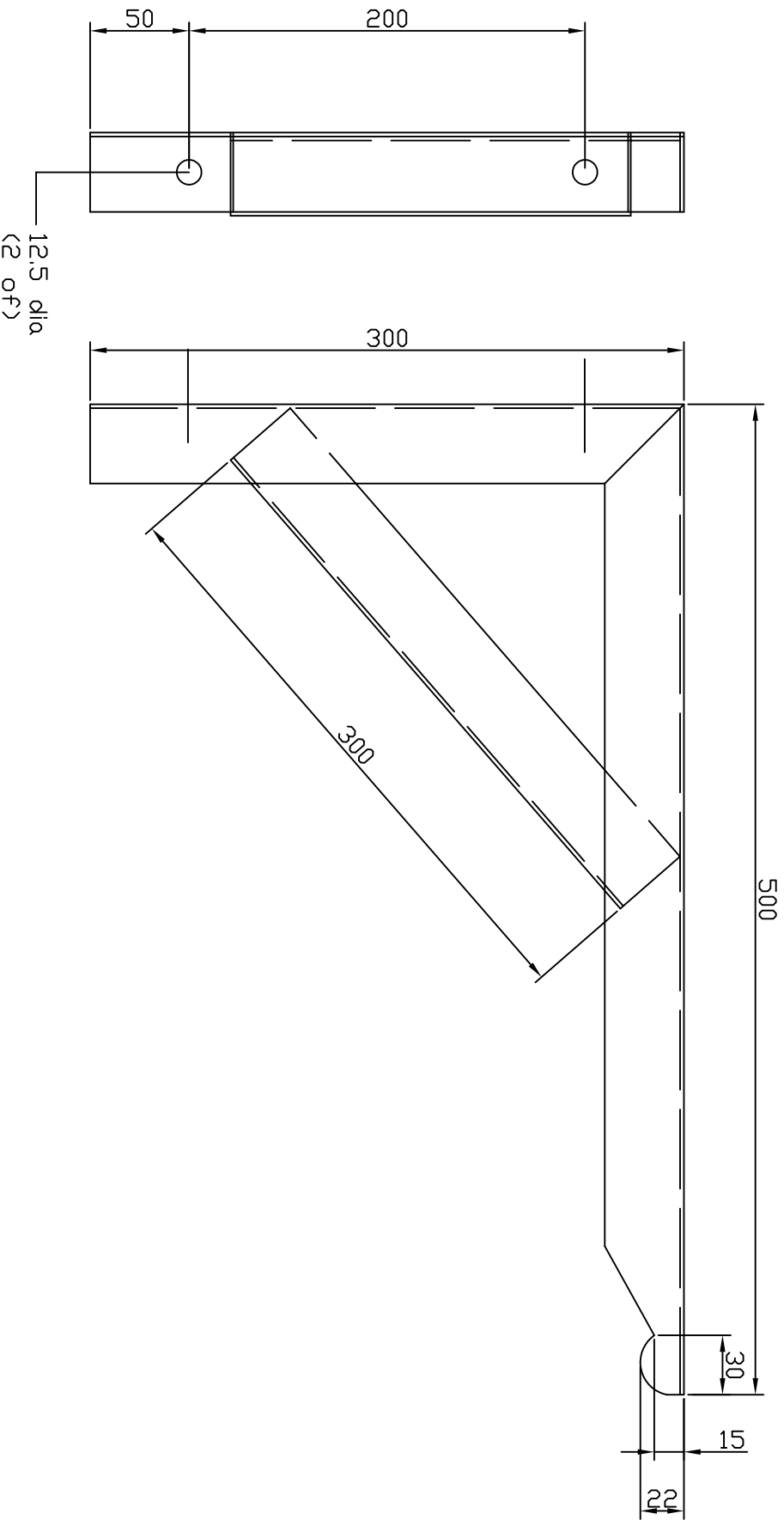

HANDLE FOR
TRAY DRYER -
MILD STEEL -
1 OFF
TOLERANCES
UNLESS OTHERWISE
STATED +/- 0.25

Practical Action www.practicalaction.org info@practicalaction.org.uk		TITLE	TRAY DRYER	DRAWN	TRACE	CHK	NOT TO SCALE
DIMENSIONS IN MM				A/R	-	-	
No. REVISIONS	Description	CHK	AP'D	DATE			

DRAWING No. TD017