



# ***Biogas Digest***

**Volume I**

**Biogas Basics**



**Information and Advisory Service  
on Appropriate Technology**



## **Imprint**

This information service on biogas technology has been developed and produced on the order of the GTZ project Information and Advisory Service on Appropriate Technology (ISAT) for the ISAT Website in a collaborative effort of the following institutions and individuals:

### **Concept and contents:**

#### **Werner Kossmann, Uta Pönitz**

*Information and Advisory Service on Appropriate Technology (ISAT)  
GATE in Deutsche Gesellschaft für Technische Zusammenarbeit (GTZ), GmbH  
(German Agency for Technical Cooperation)  
Post Box 5180  
D-65726 Eschborn  
Federal Republic of Germany  
Telephone: +49 6196/79-0  
Fax: +49 6196/797352  
E-mail: gate-isat@gtz.de*

#### **Stefan Habermehl**

*Household Energy Appropriate Technologies (HEAT) GmbH  
Limburger Straße 29  
D-61479 Glashütten  
Federal Republic of Germany  
Telephone: +49 6174 964077  
Fax: +49 6174 61209  
E-mail: heatinternational@t-online.de*

#### **Thomas Hoerz, Pedro Krämer, B. Klingler, C. Kellner, Thomas Wittur, F. v. Klopotek, A. Krieg, H. Euler**

*Naturrechte Technologien, Bau- und Wirtschaftsberatung (TBW) GmbH  
Baumweg 10  
60316 Frankfurt  
Tel.: 069 943507-0  
Fax: 069 943507-11  
E-mail: tbw@pop-frankfurt.com*

### **Design:**

*Utz Dornberger  
Stöckelstr. 20  
04347 Leipzig  
Tel.: 0341 2334980  
E-mail: utz@imb-jena.de*

# Table of Contents

<b>Biogas Basics</b> .....	<b>4</b>
What is biogas?.....	4
Biogas and the global carbon cycle .....	4
Biology of methanogenesis.....	4
Substrate and material balance of biogas production.....	4
Composition and properties of biogas .....	4
Utilization .....	5
The Benefits of Biogas Technology .....	5
The Costs of Biogas Technology .....	6
Fuel and Fertilizer.....	6
Public and Political Awareness.....	6
<b>History of Biogas Technology</b> .....	<b>7</b>
Europe/Germany.....	7
China and India.....	7
German promotion of biogas technology in the south .....	7
Outlook .....	8
<b>Microbiology</b> .....	<b>9</b>
The three steps of biogas production .....	9
Hydrolysis.....	9
Acidification .....	9
Methane formation.....	10
Symbiosis of bacteria.....	10
<b>Parameters and process optimisation</b> .....	<b>11</b>
Substrate temperature .....	11
Available nutrient .....	11
Retention time.....	12
pH value.....	12
Nitrogen inhibition and C/N ratio .....	12
Biodegradable material.....	13
Substrate solids content and agitation.....	14
Inhibitory factors .....	14
<b>The Physical Appearance of Different Types of Biogas Plants</b> .....	<b>16</b>
Balloon plants .....	16
Fixed-dome plants .....	17
Floating-drum plants.....	17
<b>Biogas Appliances</b> .....	<b>19</b>
Gas cookers/stoves.....	19
Biogas lamps.....	20
Radiant heaters.....	22
Incubators .....	22
Refrigerators .....	23
Biogas-fueled engines.....	23
<b>Organic Fertilizer from Biogas Plants</b> .....	<b>26</b>
Organic substances in fertilizers .....	26
Nutrients and soil organisms.....	26
Reduction of soil erosion .....	26
<b>The Contribution of Biogas Technology to Conservation and Development</b> .....	<b>28</b>
Conservation.....	28
Development.....	28
<b>Limitations of Biogas Technology</b> .....	<b>30</b>
<b>Biogas - Framework Conditions</b> .....	<b>32</b>
Social aspects in the planning process .....	32
Social and political aspects in the dissemination process .....	32
Specific regional developments .....	32

National energy & fertilizer supply strategies .....	33
Environmental aspects .....	33
<b>Socio-Cultural Aspects of Biogas Projects.....</b>	<b>35</b>
Participation.....	35
Religious and social taboos.....	35
Social classes and class barriers.....	36
Social regulations for the division of labor.....	37
Gender considerations.....	38
<b>Social Problems Affecting the Propagation of Biogas Technology .....</b>	<b>39</b>
Ethical barriers.....	39
Socio-cultural taboos .....	39
Defense mechanisms against the use of human excrements as fertilizer .....	39
Irregular attendance and maintenance of biogas systems .....	40
Fertilization.....	40
<b>Political and Administrative Frame Conditions for Biogas Programmes.....</b>	<b>41</b>
Political will and public opinion.....	41
Program goals .....	42
Administration.....	42
<b>Environmental Frame Conditions of Biogas Technology .....</b>	<b>43</b>
Climatic conditions for biogas dissemination.....	43
Firewood consumption and soil erosion .....	44
Reduction of the greenhouse effect.....	45

# Biogas Basics

## What is biogas?

Biogas originates from bacteria in the process of bio-degradation of organic material under anaerobic (without air) conditions. The natural generation of biogas is an important part of the biogeochemical carbon cycle. Methanogens (methane producing bacteria) are the last link in a chain of micro-organisms which degrade organic material and return the decomposition products to the environment. In this process biogas is generated, a source of renewable energy.

## Biogas and the global carbon cycle

Each year some 590-880 million tons of methane are released worldwide into the atmosphere through microbial activity. About 90% of the emitted methane derives from biogenic sources, i.e. from the decomposition of biomass. The remainder is of fossil origin (e.g. petrochemical processes). In the northern hemisphere, the present tropospheric methane concentration amounts to about 1.65 ppm.

## Biology of methanogenesis

Knowledge of the fundamental processes involved in methane fermentation is necessary for planning, building and operating biogas plants. Anaerobic fermentation involves the activities of three different bacterial communities. The process of biogas-production depends on various parameters. For example, changes in ambient temperature can have a negative effect on bacterial activity.

## Substrate and material balance of biogas production

In principle, all organic materials can ferment or be digested. However, only homogenous and liquid substrates can be considered for simple biogas plants: faeces and urine from cattle, pigs and possibly from poultry and the wastewater from toilets. When the plant is filled, the excrement has to be diluted with about the same quantity of liquid, if possible, the urine should be used. Waste and wastewater from food-processing industries are only suitable for simple plants if they are homogenous and in liquid form. The maximum of gas-production from a given amount of raw material depends on the type of substrate.

## Composition and properties of biogas

Biogas is a mixture of gases that is composed chiefly of:

- **methane** (CH<sub>4</sub>): 40-70 vol.%
- **carbon dioxide** (CO<sub>2</sub>): 30-60 vol.%
- **other gases**: 1-5 vol.%  
including
  - hydrogen (H<sub>2</sub>): 0-1 vol.%
  - hydrogen sulfide (H<sub>2</sub>S): 0-3 vol.%

Like those of any pure gas, the **characteristic properties** of biogas are pressure and temperature-dependent. They are also affected by the moisture content. The factors of main interest are:

- change in volume as a function of temperature and pressure,
- change in calorific value as a function of temperature, pressure and water-vapor content, and
- change in water-vapor content as a function of temperature and pressure.



The **calorific value** of biogas is about 6 kWh/m<sup>3</sup> - this corresponds to about half a litre of diesel oil. The net calorific value depends on the efficiency of the burners or appliances. Methane is the valuable component under the aspect of using biogas as a fuel.

## Utilization

The history of biogas utilization shows independent developments in various developing and industrialized countries. The European biogas-history and that of Germany in particular, as well as developments in Asian countries form the background of German efforts and programmes to promote biogas technology worldwide.

Normally, the biogas produced by a digester can be used as it is, just in the same way as any other combustible gas. But it is possible that a further treatment or conditioning is necessary, for example, to reduce the hydrogen-sulfide content in the gas. When biogas is mixed with air at a ratio of 1:20, a highly explosive gas forms. Leaking gas pipes in enclosed spaces constitute, therefore, a hazard. However, there have been no reports of dangerous explosions caused by biogas so far.

A first overview of the physical appearance of different types of biogas plants describes the three main types of simple biogas plants, namely balloon plants, fixed-dome plants and floating-drum plants.

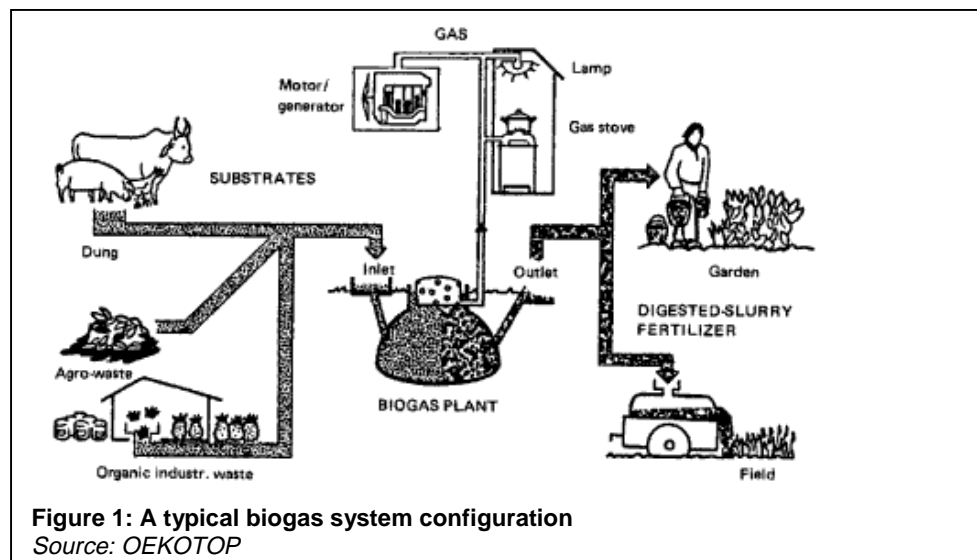

Figure 1: A typical biogas system configuration  
Source: OEKOTOP

## The Benefits of Biogas Technology

Well-functioning biogas systems can yield a whole range of benefits for their users, the society and the environment in general:

- production of energy (heat, light, electricity) ;
- transformation of organic waste into high quality fertilizer;
- improvement of hygienic conditions through reduction of pathogens, worm eggs and flies;
- reduction of workload, mainly for women, in firewood collection and cooking.
- environmental advantages through protection of soil, water, air and woody vegetation;
- micro-economical benefits through energy and fertilizer substitution, additional income sources and increasing yields of animal husbandry and agriculture;
- macro-economical benefits through decentralized energy generation, import substitution and environmental protection

Thus, biogas technology can substantially contribute to conservation and development, if the concrete conditions are favorable. However, the required high investment capital and other limitations of biogas technology should be thoroughly considered.

### **The Costs of Biogas Technology**

An obvious obstacle to the large-scale introduction of biogas technology is the fact that the poorer strata of rural populations often cannot afford the investment cost for a biogas plant. This is despite the fact that biogas systems have proven economically viable investments in many cases.

Efforts have to be made to reduce construction cost but also to develop credit and other financing systems. A larger numbers of biogas operators ensures that, apart from the private user, the society as a whole can benefit from biogas. Financial support from the government can be seen as an investment to reduce future costs, incurred through the importation of petrol products and inorganic fertilizers, through increasing costs for health and hygiene and through natural resource degradation.

### **Fuel and Fertilizer**

In developing countries, there is a direct link between the problem of fertilization and progressive deforestation due to high demand for firewood. In many rural areas, most of the inhabitants are dependant on dung and organic residue as fuel for cooking and heating. Such is the case, for example, in the treeless regions of India (Ganges plains, central highlands), Nepal and other countries of Asia, as well as in the Andes Mountains of South America and wide expanses of the African Continent. According to data published by the FAO, some 78 million tons of cow dung and 39 million tons of phytogetic waste were burned in India alone in 1970. That amounts to approximately 35% of India's total noncommercial/nonconventional energy consumption.

The burning of dung and plant residue is a considerable waste of plant nutrients. Farmers in developing countries are in dire need of fertilizer for maintaining cropland productivity. Nonetheless, many small farmers continue to burn potentially valuable fertilizers, even though they cannot afford to buy chemical fertilizers. At the same time, the amount of technically available nitrogen, pottasium and phosphorous in the form of organic materials is around eight times as high as the quantity of chemical fertilizers actually consumed in developing countries. Especially for small farmers, biogas technology is a suitable tool for making maximum use of scarce resources: After extraction of the energy content of dung and other organic waste material, the resulting sludge is still a good fertilizer, supporting general soil quality as well as higher crop yields.

### **Public and Political Awareness**

Popularization of biogas technology has to go hand in hand with the actual construction of plants in the field. Without the public awareness of biogas technology, its benefits and pitfalls, there will be no sufficient basis to disseminate biogas technology at grassroots level. At the same time, awareness within the government is essential. Since impacts and aspects of biogas technology concern so many different governmental institutions (e.g. agriculture, environment, energy, economics), it is necessary to identify and include all responsible government departments in the dissemination and awareness-raising process.

# History of Biogas Technology

## Europe/Germany

- 1770 The Italian Volta collected marsh gas and investigated its burning behavior.
- 1821 Avogadro identified methane (CH<sub>4</sub>).
- 1875 Propoff states that biogas is produced under anaerobic conditions.
- 1884 Pasteur researched on biogas from animal residues. He proposed the utilization of horse litter to produce biogas for street-lighting.
- 1906 First anaerobic wastewater-treatment plant in Germany.
- 1913 First anaerobic digester with heating facility.
- 1920 First German sewage plant to feed the collected biogas into the public gas supply system.
- 1940 Addition of organic residues (fat) to increase sewage gas production.
- 1947 Research demonstrates that the dung of one cow can give a hundred times more gas than the feces of one urban inhabitant.  
Establishment of the first working group on biogas in Germany.
- 1950 Installation of the first larger agricultural biogas plant.
- 1950s Nearly 50 biogas plants are built, fed by litter mixed with water and dung. Low oil prices and technical problems lead to the shutdown of all but two plants.
- 1974 After the first 'energy crisis', increased promotion of research on and implementation of agricultural biogas technology by the EC and federal departments.
- 1985 75 biogas plants are listed (built or planned). Biogas slurry is increasingly used as liquid manure.
- 1990 Progress due to guaranteed prices for biogas-generated electricity. Progress in optimizing the mixture of substrates, the use of biogas for different purposes and technology details.
- 1992 Foundation of the German biogas association 'Fachverband Biogas'
- 1997 More than 400 agricultural biogas plants exist in Germany.

## China and India

The history of biogas exploration and utilization in China covers a period of more than 50 years. First biogas plants were built in the 1940s by prosperous families. Since the 1970s biogas research and technology were developed at a high speed and biogas technology was promoted vigorously by the Chinese government. In rural areas, more than 5 million small biogas digesters have been constructed and, currently, over 20 million persons use biogas currently as a fuel.

In India, the development of simple biogas plants for rural households started in the 1950s. A massive increase in the number of biogas plants took place in the 1970s through strong government backing. Meanwhile, more than one million biogas plants exist in India.

The historical experiences in Germany, China and India demonstrate clearly, how biogas development responds to favorable frame conditions. In Germany, biogas dissemination gained momentum through the need for alternative energy sources in a war-torn economy and during an energy crisis or later by the change of electricity pricing. In India and China it was a strong government program that furthered the mass dissemination of biogas technology.

## German promotion of biogas technology in the south

In the late 1970's, triggered by Schuhmacher's 'Small is Beautiful', appropriate, simple technologies entered the arena of development work in the South. Not Northern high-tech, but innovative, affordable, simple and traditional technologies, it was believed, were the



remedy for the development- and technology-gap between industrialized and developing countries. Following its launching in 1980, GTZ-GATE chose biogas technology as a focal point of its activities. This resulted in a cross-sectoral scheme that has been accompanying and supporting the development and dissemination of biogas technology in Latin America, Asia and Africa.

Industrialized countries neither had sufficient experience nor appropriate technologies to build on in developing countries. Rather, this experience was identified in India and China and transmitted by a South-North-South transfer. The term 'appropriate technology' seemed justified by the fact that this technology was adapted to the respective local conditions during a 'learning-with-developing-countries' process.

A number of biogas dissemination programs involving German Technical Cooperation (GTZ) were launched in Bolivia, Colombia, Nicaragua, the Caribbean (see Belize and Jamaica), Tanzania, Kenya, Burundi, Morocco and Thailand. Initially, biogas and anaerobic technology focused on small scale farmers. At a later stage, larger farms as well as waste treatment issues increasingly became the focus of biogas technology.

These activities have resulted in a number of positive spin-off effects in the partner countries, in Germany, Europe and international development cooperation. Like in other fields of appropriate technology (AT) promotion, environmental protection, energy provision and the support to private enterprise development are increasingly seen as inseparable elements of sustainable (technology) development.

## **Outlook**

Today, the highest degree of market maturity can be found in the area of municipal sludge treatment, industrial wastewater purification and treatment of agricultural wastes. The use of the technology in municipal wastewater treatment is currently experiencing an upswing in Asia (India in particular) and Latin America. Anaerobic treatment of municipal organic waste is experiencing a boom in Northern Europe. Agricultural biogas plants in developing countries are usually promoted on a large scale in connection with energy and environmental issues, and are installed particularly where water pollution through liquid manure from agriculture is most severe.

The increasing emission of greenhouse gases, increasing water consumption and water pollution, declining soil fertility, unsatisfactory waste management and the growing rate of deforestation must be seen as parts of the unsustainable resource use systems that prevail worldwide. Biogas technology is one of the important hardware components in a chain of measures to counteract the above problems. GATE/ISAT is committed to play a lead role in networking and information exchange to ensure that the potential of biogas technology is recognized and made optimal use of.

# Microbiology

## The three steps of biogas production

Biogas microbes consist of a large group of complex and differently acting microbe species, notable the methane-producing bacteria. The whole biogas-process can be divided into three steps: hydrolysis, acidification, and methane formation (Figure 2). Three types of bacteria are involved (Figure 3).

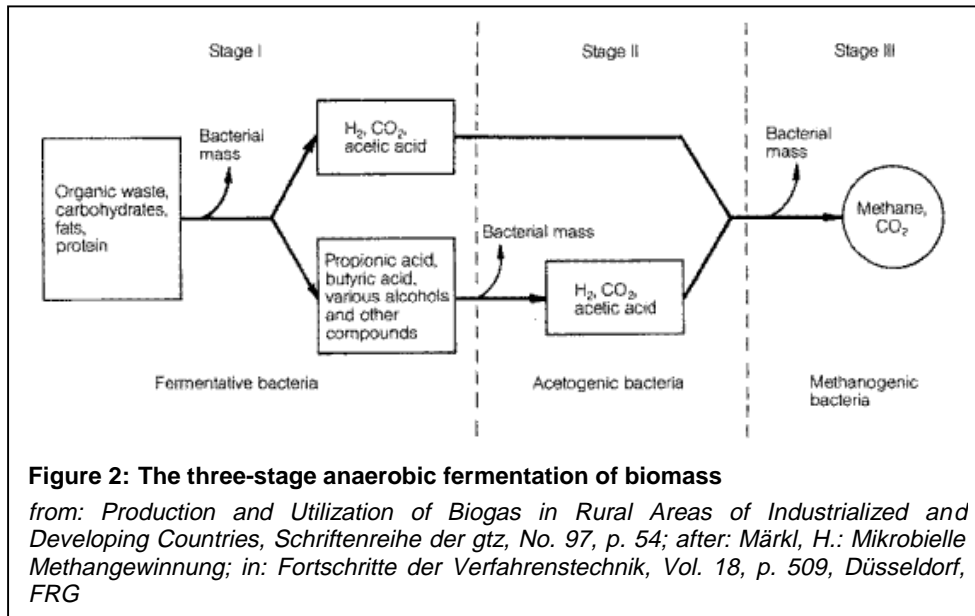

**Figure 2: The three-stage anaerobic fermentation of biomass**

from: *Production and Utilization of Biogas in Rural Areas of Industrialized and Developing Countries*, Schriftenreihe der gtz, No. 97, p. 54; after: Märkl, H.: *Mikrobielle Methangewinnung*; in: *Fortschritte der Verfahrenstechnik*, Vol. 18, p. 509, Düsseldorf, FRG

## Hydrolysis

In the first step (hydrolysis), the organic matter is enzymolyzed externally by extracellular enzymes (cellulase, amylase, protease and lipase) of microorganisms. Bacteria decompose the long chains of the complex carbohydrates, proteins and lipids into shorter parts. For example, polysaccharides are converted into monosaccharides. Proteins are split into peptides and amino acids.

## Acidification

Acid-producing bacteria, involved in the second step, convert the intermediates of fermenting bacteria into acetic acid ( $\text{CH}_3\text{COOH}$ ), hydrogen ( $\text{H}_2$ ) and carbon dioxide ( $\text{CO}_2$ ). These bacteria are facultatively anaerobic and can grow under acid conditions. To produce acetic acid, they need oxygen and carbon. For this, they use the oxygen solved in the solution or bounded-oxygen. Hereby, the acid-producing bacteria create an anaerobic condition which is essential for the methane producing microorganisms. Moreover, they reduce the compounds with a low molecular weight into alcohols, organic acids, amino acids, carbon dioxide, hydrogen sulphide and traces of methane. From a chemical standpoint, this process is partially endergonic (i.e. only possible with energy input), since bacteria alone are not capable of sustaining that type of reaction.

Acid-producing bacteria, involved in the second step, convert the intermediates of fermenting bacteria into acetic acid ( $\text{CH}_3\text{COOH}$ ), hydrogen ( $\text{H}_2$ ) and carbon dioxide ( $\text{CO}_2$ ). These bacteria are facultatively anaerobic and can grow under acid conditions. To produce acetic acid, they need oxygen and carbon. For this, they use the oxygen solved in the solution or bound oxygen. Hereby, the acid-producing bacteria create an anaerobic condition which is essential for the methane producing microorganisms. Moreover, they reduce the compounds with a low molecular weight into alcohols, organic acids, amino acids, carbon dioxide, hydrogen sulphide and traces of methane. From a chemical standpoint, this process is

partially endergonic (i.e. only possible with energy input), since bacteria alone are not capable of sustaining that type of reaction.

## Methane formation

Methane-producing bacteria, involved in the third step, decompose compounds with a low molecular weight. For example, they utilize hydrogen, carbon dioxide and acetic acid to form methane and carbon dioxide. Under natural conditions, methane producing microorganisms occur to the extent that anaerobic conditions are provided, e.g. under water (for example in marine sediments), in ruminant stomachs and in marshes. They are obligatory anaerobic and very sensitive to environmental changes. In contrast to the acidogenic and acetogenic bacteria, the methanogenic bacteria belong to the archaeobacter genus, i.e. to a group of bacteria with a very heterogeneous morphology and a number of common biochemical and molecular-biological properties that distinguish them from all other bacterial general. The main difference lies in the makeup of the bacteria's cell walls.

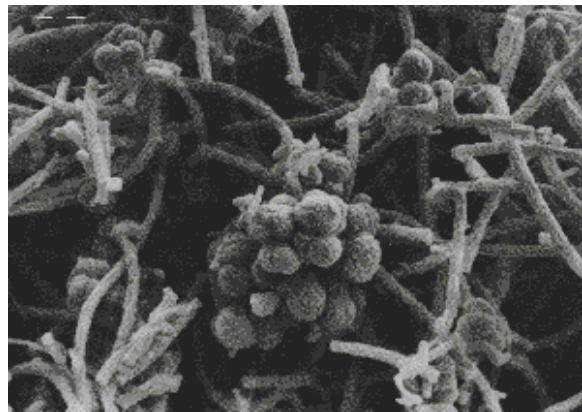

**Figure 3: Various types of methanogenic bacteria. The spherically shaped bacteria are of the *methanosarcina* genus; the long, tubular ones are *methanothrix* bacteria, and the short, curved rods are bacteria that catabolize furfural and sulfates. The total length of the broken bar at top left, which serves as a size reference, corresponds to 1 micron.**

*Source: Production and Utilization of Biogas in Rural Areas of Industrialized and Developing Countries, Schriftenreihe der gtz, No. 97, p. 55*

## Symbiosis of bacteria

Methane- and acid-producing bacteria act in a symbiotical way. On the one hand, acid-producing bacteria create an atmosphere with ideal parameters for methane-producing bacteria (anaerobic conditions, compounds with a low molecular weight). On the other hand, methane-producing microorganisms use the intermediates of the acid-producing bacteria. Without consuming them, toxic conditions for the acid-producing microorganisms would develop.

In practical fermentation processes the metabolic actions of various bacteria all act in concert. No single bacteria is able to produce fermentation products alone.

## Parameters and process optimisation

The metabolic activity involved in microbiological methanation is dependent on the following factors:

- Substrate temperature
- Available nutrients
- Retention time (flow-through time)
- pH level
- Nitrogen inhibition and C/N ratio
- Substrat solid content and agitation
- Inhibitory factors

Each of the various types of bacteria responsible for the three stages of the methanogenesis is affected differently by the above parameters. Since interactive effects between the various determining factors exist, no precise quantitative data on gas production as a function of the above factors are available. Thus, discussion of the various factors is limited to their qualitative effects on the process of fermentation.

---

### Substrate temperature

#### Temperature range of anaerobic fermentation

Anaerobic fermentation is in principle possible between 3°C and approximately 70°C. Differentiation is generally made between three temperature ranges:

- The *psychrophilic temperature range* lies below 20°C,
- the *mesophilic temperature range* between 20°C and 40°C and
- the *thermophilic temperature range* above 40°C.

#### Minimal average temperature

The rate of bacteriological methane production increases with temperature. Since, however, the amount of free ammonia also increases with temperature, the bio-digestive performance could be inhibited or even reduced as a result. In general, unheated biogas plants perform satisfactory only where mean annual temperatures are around 20°C or above or where the average daily temperature is at least 18°C. Within the range of 20-28°C mean temperature, gas production increases over-proportionally. If the temperature of the bio-mass is below 15°C, gas production will be so low that the biogas plant is no longer economically feasible.

#### Changes in temperature

The process of bio-methanation is very sensitive to *changes* in temperature. The degree of sensitivity, in turn, is dependent on the temperature range. Brief fluctuations not exceeding the following limits may be regarded as still un-inhibitory with respect to the process of fermentation:

- psychrophilic range:  $\pm 2^\circ\text{C}/\text{h}$
- mesophilic range:  $\pm 1^\circ\text{C}/\text{h}$
- thermophilic range:  $\pm 0,5^\circ\text{C}/\text{h}$

The temperature fluctuations between day and night are no great problem for plants built underground, since the temperature of the earth below a depth of one meter is practically constant.

#### Available nutrient

In order to grow, bacteria need more than just a supply of organic substances as a source of carbon and energy. They also require certain mineral nutrients. In addition to *carbon*, *oxygen* and *hydrogen*, the generation of bio-mass requires an adequate supply of *nitrogen*, *sulfur*,

*phosphorous, potassium, calcium, magnesium* and a number of trace elements such as *iron, manganese, molybdenum, zinc, cobalt, selenium, tungsten, nickel* etc. "Normal" substrates such as agricultural residues or municipal sewage usually contain adequate amounts of the mentioned elements. Higher concentration of any individual substance usually has an inhibitory effect, so that analyses are recommended on a case-to-case basis to determine which amount of which nutrients, if any, still needs to be added.

## **Retention time**

### **Batch-type and continuous plants**

The retention time can only be accurately defined in batch-type facilities. For continuous systems, the mean retention time is approximated by dividing the digester volume by the daily influent rate. Depending on the vessel geometry, the means of mixing, etc., the effective retention time may vary widely for the individual substrate constituents. Selection of a suitable retention time thus depends not only on the process temperature, but also on the type of substrate used.

### **Cost efficiency**

Optimizing the process parameters *retention time - process temperature - substrate quality - volumetric load* determine, among others, the cost efficiency of the biological processes. But as each m<sup>3</sup> digester volume has its price, heating equipment can be costly and high quality substrates may have alternative uses, the cost-benefit optimum in biogas production is almost always below the biological optimum.

### **Substrate**

For liquid manure undergoing fermentation in the mesophilic temperature range, the following approximate values apply:

- liquid cow manure: 20-30 days
- liquid pig manure: 15-25 days
- liquid chicken manure: 20-40 days
- animal manure mixed with plant material: 50-80 days

If the retention time is too short, the bacteria in the digester are "washed out" faster than they can reproduce, so that the fermentation practically comes to a standstill. This problem rarely occurs in agricultural biogas systems.

## **pH value**

The methane-producing bacteria live best under neutral to slightly alkaline conditions. Once the process of fermentation has stabilized under anaerobic conditions, the pH will normally take on a value of between 7 and 8.5. Due to the buffer effect of carbon dioxide-bicarbonate (CO<sub>2</sub> - HCO<sub>3</sub><sup>-</sup>) and ammonia-ammonium (NH<sub>3</sub> - NH<sub>4</sub><sup>+</sup>), the pH level is rarely taken as a measure of substrate acids and/or potential biogas yield. A digester containing a high volatile-acid concentration requires a somewhat higher-than-normal pH value. If the pH value drops below 6.2, the medium will have a toxic effect on the methanogenic bacteria.

## **Nitrogen inhibition and C/N ratio**

### **Nitrogen inhibition**

All substrates contain nitrogen. Tabelle 1 lists the nitrogen content of various organic substances and the C/N ratio. For higher pH values, even a relatively low nitrogen concentration may inhibit the process of fermentation. Noticeable inhibition occurs at a nitrogen concentration of roughly 1700 mg ammonium-nitrogen (NH<sub>4</sub>-N) per liter substrate. Nonetheless, given enough time, the methanogens are capable of adapting to NH<sub>4</sub>-N concentrations in the range of 5000-7000 mg/l substrate, the main prerequisite being that the ammonia level (NH<sub>3</sub>) does not exceed 200-300 mg NH<sub>3</sub>-N per liter substrate. The rate of

ammonia dissociation in water depends on the process temperature and ph value of the substrate slurry.

**Table 1: Nitrogen-content and C/N-ratio data for a selection of substrates, compiled from various sources**

Source	Biodegradable material	N in [%]	C/N
Maramba, Felix: Biogas and Waste Recycling - The Phillipine Experience; Metro Manila, Phillipines, 1978, p. 43	A. Animal Dung		
	1. Hog	2.8	13.7
	2. Carabao	1.6	23.1
	3. Cow	1.8	19.9
	4. Chicken	3.7	9.65
	5. Duck	0.8	27.4
	6. Pugo	5.0	6.74
	Household Wastes		
	1. Nightsoil	7.1	6.72
	2. Kitchen waste	1.9	28.60
	C. Crop Residues (air-dry)		
	1. Corn stalks	1.2	56.6
	2. Rice straw	0.7	51.0
	3. Corn cobs	1.0	49.9
	4. Peanut hulls	1.7	31.0
	5. Cogon	1.07	-
	6. Bagasse	0.40	-
	D. Others		
	1. Kangkong	4.3	7.8
	2. Water lily	2.9	11.4
	3. Grass trimmings	2.5	15.7
Barnett, A. et al.: Biogas Technology in the Third World; Ottawa, Canada, 1978, p. 51	Night soil	6	6-10
	Cow manure	1.7	18
	Chicken manure	6.3	7.3
	Horse manure	2.3	25
	Hay, grass	4	12
	Hay, alfalfa	2.8	17
	Seaweed	1.9	79
	Oat straw	1.1	48
	Wheat straw	0.5	150
	Bagasse	0.3	150
	Sawdust	0.1	200-500
	Night soil	6.0	5.9-10
	Cow manure	1.7	16.6-25
	Pig manure	3.8	6.2-12.5
Kaltwasser, Bernd: Biogas; Wiesbaden, FRG, 1980, pp. 35-36	Chicken droppings	6.3	5-7.1
	Horse manure	2.3	25
	Sheep manure	3.8	33
	Hay	4.0	12.5-25
	Lucernes	2.8	16.6
	Algae	1.9	100
	Oat straw	1.1	50
	Wheat straw	0.5	100-125
	Cane trash (bagasse)	0.3	140
	Sawdust	0.1	200-500
	Cabbage	3.6	12.5
	Tomatoes	3.3	12.5
	Mustard (runch)	1.5	25
	Potato peels	1.5	25
	Rice straw	0.6	67
	Corn straw	0.8	50
	Fallen leaves	1.0	50
	Soybean stalks	1.3	33
	Peanut shoots	0.6	20

Source: Production and Utilization of Biogas in Rural Areas of Industrialized and Developing Countries, Schriftenreihe der gtz, No. 97, pp. 71-72

## **C/N ratio**

Microorganisms need both nitrogen and carbon for assimilation into their cell structures. Various experiments have shown that the metabolic activity of methanogenic bacteria can be optimized at a C/N ratio of approximately 8-20, whereby the optimum point varies from case to case, depending on the nature of the substrate.

## **Substrate solids content and agitation**

### **Substrate solids content**

The mobility of the methanogens within the substrate is gradually impaired by an increasing solids content, and the biogas yield may suffer as a result. However, reports of relatively high biogas yields from landfill material with a high solids content may be found in recent literature. No generally valid guidelines can be offered with regard to specific biogas production for any particular solids percentage.

### **Agitation**

Many substrates and various modes of fermentation require some sort of substrate agitation or mixing in order to maintain process stability within the digester. The most important objectives of agitation are:

- removal of the metabolites produced by the methanogens (gas)
- mixing of fresh substrate and bacterial population (inoculation)
- preclusion of scum formation and sedimentation
- avoidance of pronounced temperature gradients within the digester
- provision of a uniform bacterial population density
- prevention of the formation of dead spaces that would reduce the effective digester volume.

In selecting or designing a suitable means of agitation, the following points should be considered:

1. The process involves a symbiotic relationship between various strains of bacteria, i.e. the metabolite from one species can serve as nutrient for the next species, etc. Whenever the bacterial community is disrupted, the process of fermentation will remain more or less unproductive until an equivalent new community is formed. Consequently, excessive or too frequent mixing is usually detrimental to the process. Slow stirring is better than rapid agitation.
2. A thin layer of scum must not necessarily have an adverse effect on the process. For systems in which the digester is completely filled with substrate, so that any scum always remains sufficiently wet, there is little or no danger that the extraction of gas could be impeded by the scum.
3. Some types of biogas systems can function well without any mechanical agitation at all. Such systems are usually operated either on substrates with such a high solid content, that no stratification occurs, or on substrates consisting primarily of solute substances.

Since the results of agitation and mixing are highly dependent on the substrate in use, it is not possible to achieve a sufficiently uniform comparative evaluation of various mixing systems and/or intensity levels. Thus, each such system can only be designed on the basis of empirical data.

## **Inhibitory factors**

The presence of heavy metals, antibiotics (Bacitracin, Flavomycin, Lasalocid, Monensin, Spiramycin, etc.) and detergents used in livestock husbandry can have an inhibitory effect on the process of bio-methanation. The following table ( Tabelle 2) lists the limit concentrations (mg/l) for various inhibitors.

<b>Substance</b>	<b>[mg/l]</b>
<b>Copper:</b>	10-250
<b>Calcium:</b>	8000
<b>Sodium:</b>	8000
<b>Magnesium:</b>	3000
<b>Nickel:</b>	100-1000
<b>Zinc:</b>	350-1000
<b>Chromium:</b>	200-2000
<b>Sulfide (as Sulfur):</b>	200
<b>Cyanide:</b>	2

**Table 2: Limiting concentrations for various inhibitors of biomethanation**



## The Physical Appearance of Different Types of Biogas Plants

The three main types of simple biogas plants are shown in Figure 4:

- balloon plants
- fixed-dome plants
- floating-drum plants

More information about the different types of biogas plants is provided under digester types.

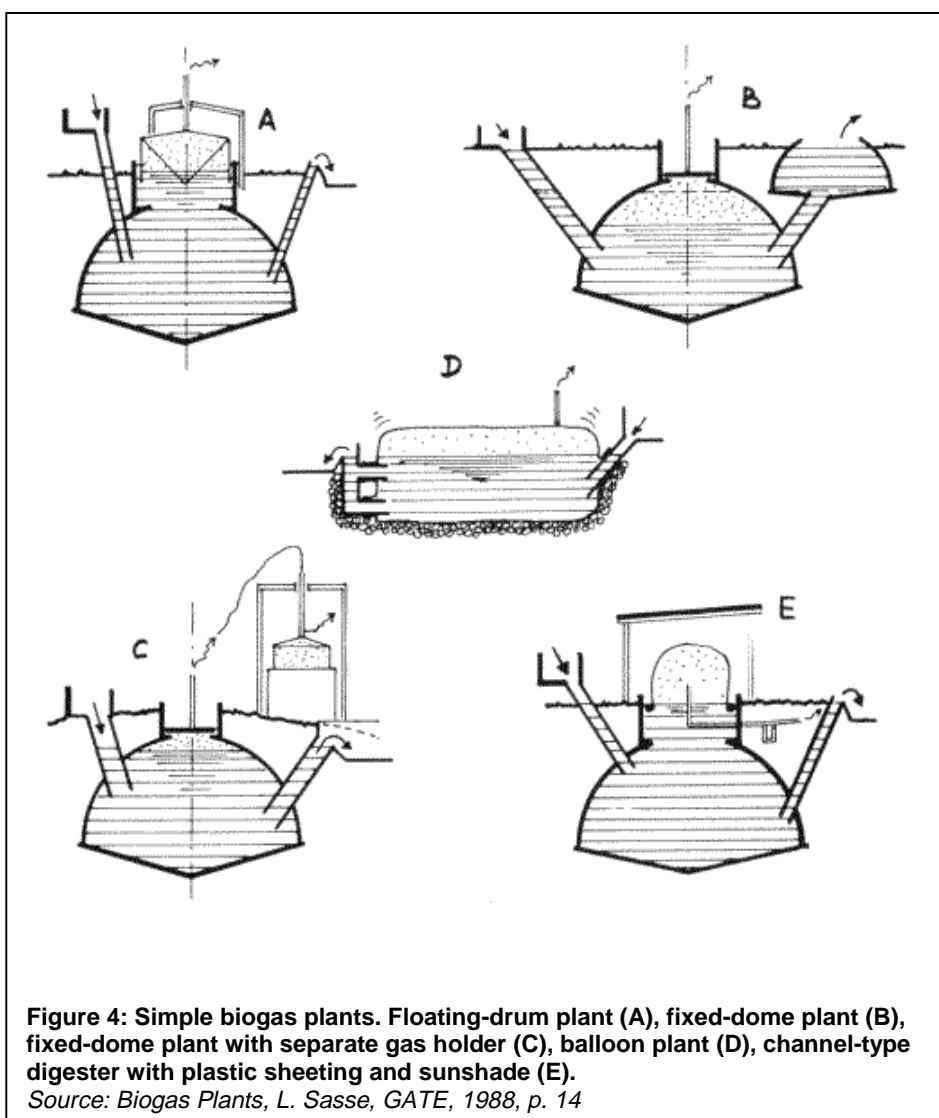

### Balloon plants

The balloon plant consists of a digester bag (e.g. PVC) in the upper part of which the gas is stored. The inlet and outlet are attached directly to the plastic skin of the balloon. The gas pressure is achieved through the elasticity of the balloon and by added weights placed on the balloon.

**Advantages** are low cost, ease of transportation, low construction sophistication, high digester temperatures, uncomplicated cleaning, emptying and maintenance.

**Disadvantages** can be the relatively short life span, high susceptibility to damage, little creation of local employment and, therefore, limited self-help potential.

A variation of the balloon plant is the **channel-type digester**, which is usually covered with plastic sheeting and a sunshade (Figure 4E). Balloon plants can be recommended wherever the balloon skin is not likely to be damaged and where the temperature is even and high.



**Figure 5: Small "foil-plant" (Ivory Coast)**

*Photo: Henning*

### **Fixed-dome plants**

The fixed-dome plant consists of a digester with a fixed, non-movable gas holder, which sits on top of the digester. When gas production starts, the slurry is displaced into the compensation tank. Gas pressure increases with the volume of gas stored and the height difference between the slurry level in the digester and the slurry level in the compensation tank.

**Advantages** are the relatively low construction costs, the absence of moving parts and rusting steel parts. If well constructed, fixed dome plants have a long life span. The underground construction saves space and protects the digester from temperature changes. The construction provides opportunities for skilled local employment.

**Disadvantages** are mainly the frequent problems with the gas-tightness of the brickwork gas holder (a small crack in the upper brickwork can cause heavy losses of biogas). Fixed-dome plants are, therefore, recommended only where construction can be supervised by experienced biogas technicians. The gas pressure fluctuates substantially depending on the volume of the stored gas. Even though the underground construction buffers temperature extremes, digester temperatures are generally low.

### **Floating-drum plants**

Floating-drum plants consist of an underground digester and a moving gas-holder. The gas-holder floats either directly on the fermentation slurry or in a water jacket of its own. The gas is collected in the gas drum, which rises or moves down, according to the amount of gas stored. The gas drum is prevented from tilting by a guiding frame. If the drum floats in a water jacket, it cannot get stuck, even in substrate with high solid content.

**Advantages** are the simple, easily understood operation - the volume of stored gas is directly visible. The gas pressure is constant, determined by the weight of the gas holder. The construction is relatively easy, construction mistakes do not lead to major problems in operation and gas yield.

**Disadvantages** are high material costs of the steel drum, the susceptibility of steel parts to corrosion. Because of this, floating drum plants have a shorter life span than fixed-dome plants and regular maintenance costs for the painting of the drum.

To contrast these simple biogas plants, Figure 6 gives an impression about dimensions of industrial plants which are, for example, built in Europe.

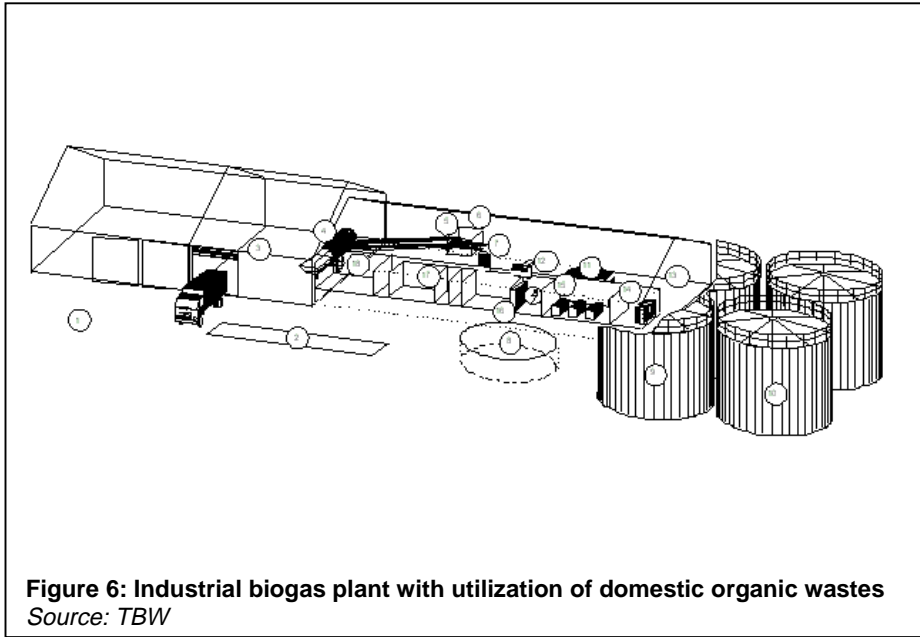

## Biogas Appliances

Biogas is a lean gas that can, in principle, be used like other fuel gas for household and industrial purposes, especially for:

- Gas cookers/stoves
- Biogas lamps
- Radiant heaters
- Incubators
- Refrigerators
- Engines

---

### Gas cookers/stoves

Biogas cookers and stoves must meet various **basic requirements**:

- simple and easy operation
- versatility, e.g. for pots of various size, for cooking and broiling
- easy to clean
- acceptable cost and easy repair
- good burning properties, i.e. stable flame, high efficiency
- attractive appearance

#### Two-flame burners

A cooker is more than just a burner. It must satisfy certain aesthetic and utility requirements, which can vary widely from region to region. Thus, there is no such thing as an all-round biogas burner. Most households prefer two-flame burners. The burners should be set initially and then fixed. Efficiency will then remain at a high practical level. Single-flame burners and lightweight cook-stoves tend to be regarded as stop-gap solutions until more suitable alternatives can be afforded.

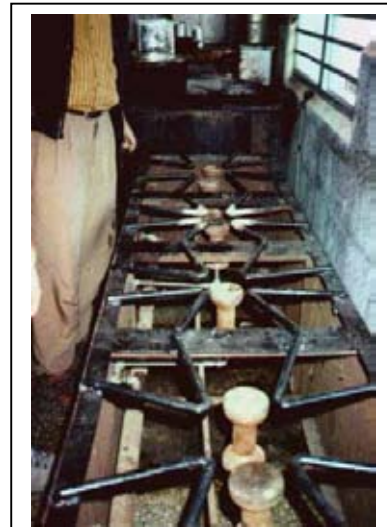

**Figure 7: Institutional burner in a community kitchen**  
*Photo: Krämer (TBW)*

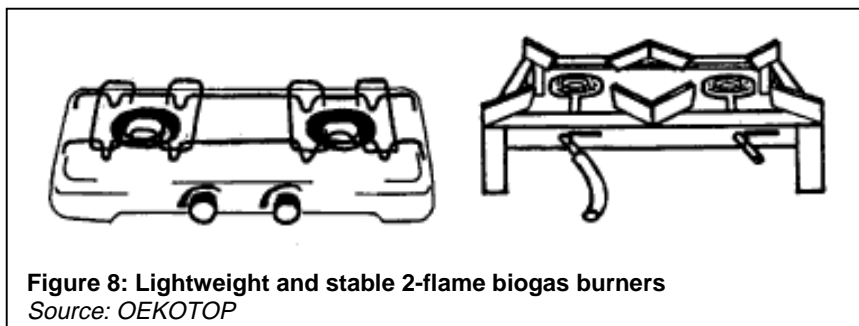

**Figure 8: Lightweight and stable 2-flame biogas burners**  
*Source: OEKOTOP*

Biogas cookers require purposeful installation with adequate protection from the wind. Before any cooker is used, the burner must be carefully adjusted, i.e.:

- for a compact, bluish flame
- the pot should be cupped by the outer cone of the flame without being touched by the inner cone

- the flame should be self-stabilizing, i.e. flameless zones must re-ignite automatically within 2 to 3 seconds

Test measurements should be performed to optimize the burner setting and minimize consumption.



**Figure 9: Biogas stove in China**  
 Photo: Grosch (gtz/GATE)

### Gas demand

The gas demand can be defined on the basis of energy consumed previously. For example, 1 kg firewood then corresponds to 200 l biogas, 1 kg dried cow dung corresponds to 100 l biogas and 1 kg charcoal corresponds to 500 l biogas.

The gas demand can also be defined using the daily cooking times. The gas consumption per person and meal lies between 150 and 300 liter biogas. For one liter water to be cooked 30-40 l biogas, for 1/2 kg rice 120-140 l and for 1/2 kg legumes 160-190 l are required.

### Biogas lamps

#### Efficiency of biogas lamps

In villages without electricity, lighting is a basic need as well as a status symbol. However, biogas lamps are not very energy-efficient. This means that they also get very hot. The bright light of a biogas lamp is the result of incandescence, i.e. the intense heat-induced luminosity of special metals, so-called "rare earth" like thorium, cerium, lanthanum, etc. at temperatures of 1000-2000°C. If they hang directly below the roof, they cause a fire hazard. The mantles do not last long. It is important that the gas and air in a biogas lamp are thoroughly mixed before they reach the gas mantle, and that the air space around the mantle is adequately warm.

#### Light output

The light output (luminous flux) is measured in lumen (lm). At 400-500 lm, the maximum light-flux values that can be achieved with biogas lamps are comparable to those of a normal 25-75 W light bulb. Their luminous efficiency ranges from 1.2 to 2 lm/W. By comparison, the overall efficiency of a light bulb comes to 3-5 lm/W, and that of a fluorescent lamp ranges from 10 to 15 lm/W. One lamp consumes about 120-150 liter biogas per day.

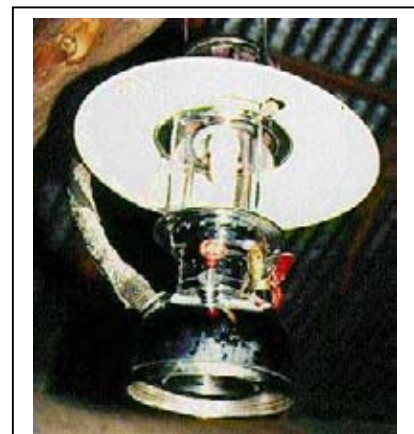

**Figure 10: Biogas lamp in Thailand**  
 Photo: Kossmann (gtz/GATE)

## Optimal tuning

The performance of a biogas lamp is dependent on optimal tuning of the incandescent body (gas mantle) and the shape of the flame at the nozzle, i.e. the incandescent body must be surrounded by the inner (=hottest) core of the flame at the minimum gas consumption rate. If the incandescent body is too large, it will show dark spots; if the flame is too large, gas consumption will be too high for the light-flux yield. The lampshade reflects the light downward, and the glass prevents the loss of heat.

## Shortcomings of commercial-type biogas lamps

Practical experience shows that commercial-type gas lamps are not optimally designed for the specific conditions of biogas combustion (fluctuating or low pressure, varying gas composition). The most frequently observed shortcomings are:

- excessively large nozzle diameters
- excessively large gas mantles
- no possibility of changing the injector
- poor or lacking means of combustion-air control

Such drawbacks result in unnecessarily high gas consumption and poor lighting. While the expert/extension officer has practically no influence on how a given lamp is designed, he can at least give due consideration to the mentioned aspects when it comes to selecting a particular model.

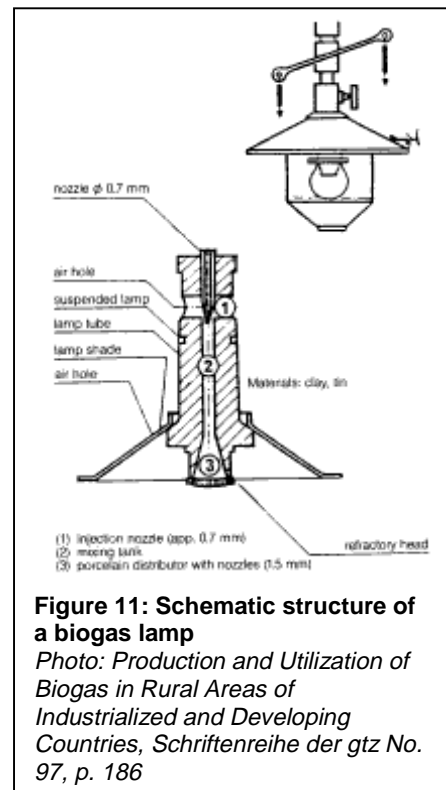

## Adjusting a biogas lamp

Biogas lamps are controlled by adjusting the supply of gas and primary air. The aim is to make the gas mantle burn with uniform brightness and a steady, sputtering murmur (sound of burning, flowing biogas). To check the criteria, place the glass on the lamp and wait 2-5 minutes, until the lamp has reached its normal operating temperature. Most lamps operate at a gas pressure of 5-15 cm WC (water column). If the pressure is any lower, the mantle will not glow, and if the pressure is too high (fixed-dome plants) the mantle may tear.



Adjusting a biogas lamp requires two consecutive steps:

1. pre-control of the supply of biogas and primary air without the mantle, initially resulting in an elongated flame with a long inner core
2. fine adjustment with the incandescent body in place, resulting in a brightly glowing incandescent body, coupled with slight further adjustment of the air supply (usually more).

The adjustment is at its best when the dark portions of the incandescent body have just disappeared. A lux-meter can be used for objective control of the lamp adjustment.

## **Radiant heaters**

Infrared heaters are used in agriculture for achieving the temperatures required for raising young stock, e.g. piglets and chicken in a limited amount of space. The nursery temperature for piglets begins at 30-35°C for the first week and then gradually drops off to an ambient temperature of 18-23°C in the 4th/5th week. As a rule, temperature control consists of raising or lowering the heater. Good ventilation is important in the stable / nursery in order to avoid excessive concentrations of CO or CO<sub>2</sub>. Consequently, the animals must be kept under regular supervision, and the temperature must be checked at regular intervals. Heaters for pig or chicken rearing require some 200-300 l/h as a rule of thumb.

### **Thermal radiation of heaters**

Radiant heaters develop their infrared thermal radiation via a ceramic body that is heated to 600-800°C (red-hot) by the biogas flame. The heating capacity of the radiant heater is defined by multiplying the gas flow by its net calorific value, since 95% of the biogas' energy content is converted to heat. Small-heater outputs range from 1.5 to 10 kW thermal power.

### **Gas pressure**

Commercial-type heaters are designed for operating on butane, propane and natural gas at a supply pressure of between 30 and 80 mbar. Since the primary air supply is factory-set, converting a heater for biogas use normally consists of replacing the injector; experience shows that biogas heaters rarely work satisfactorily because the biogas has a low net calorific value and the gas supply pressure is below 20 mbar. The ceramic panel, therefore, is not adequately heated, i.e. the flame does not reach the entire surface, and the heater is very susceptible to draft.



**Figure 14: Biogas radiant heater for raising piglets in Thailand**  
*Photo: Kossmann (gtz/GATE)*

### **Safety pilot and air filter**

Biogas-fueled radiant heaters should always be equipped with a safety pilot, which turns off the gas supply if the temperatures goes low i.e. the biogas does not burn any longer. An air filter is required for sustained operation in dusty barns.

## **Incubators**

Incubators are supposed to imitate and maintain optimal hatching temperatures for eggs. They are used to increase brooding efficiency.

### **Warm-water-heated planar-type incubators**

Indirectly warm-water-heated planar-type incubators in which a burner heats water in a heating element for circulation through the incubating chamber are suitable for operating on biogas. The temperature is controlled by ether-cell-regulated vents.

## Refrigerators

Absorption-type refrigerating machines operating on ammonia and water and equipped for automatic thermo-siphon circulation can be fuelled with biogas.

### Burner

Since biogas is only the refrigerator's external source of heat, just the burner itself has to be modified. Whenever a refrigerator is converted for operating on biogas, care must be taken to ensure that all safety features (safety pilot) function properly. Remote ignition via a piezoelectric element substantially increases the ease of operation.

### Gas demand

For 100 liters refrigeration volume, about 2000 l of biogas per day, depending on outside temperatures, must be assumed. A larger household refrigerator consumes about 3000 l per day.

## Biogas-fueled engines

### Gas demand

If the output of a biogas system is to be used for fueling engines, the plant must produce at least 10 m<sup>3</sup> biogas per day. For example, to generate 1 kWh electricity with a generator, about 1 m<sup>3</sup> biogas is required. Small-scale systems are therefore unsuitable as energy suppliers for engines.

### Types of engines

The following types of engines are, in principle, well-suited for operating on biogas:

- Four-stroke diesel engines
- Four-stroke spark-ignition engines
- Converting diesel engines
- Converting spark-ignition engines

### Four-stroke diesel engines:

A diesel engine draws air and compresses it at a ratio of 17:1 under a pressure of approximately 30-40 bar and a temperature of about 700°C. The injected fuel charge ignites itself. Power output is controlled by varying the injected amount of fuel, i.e. the air intake remains constant (so-called mixture control).

### Four-stroke spark-ignition engines:

A spark-ignition engine (gasoline engine) draws a mixture of fuel (gasoline or gas) and the required amount of combustion air. The charge is ignited by a spark plug at a comparably low compression ratio of between 8:1 and 12:1. Power control is effected by varying the mixture intake via a throttle (so-called charge control).

Four-stroke diesel and spark-ignition engines are available in standard versions with power ratings ranging from 1 kW to more than 100 kW. Less suitable for biogas fueling are:

- loop-scavenging 2-stroke engines in which lubrication is achieved by adding oil to the liquid fuel, and
- large, slow-running (less than 1000 r.p.m) engines that are not built in large series, since they are accordingly expensive and require complicated control equipment.

Biogas engines are generally suitable for powering vehicles like tractors and light-duty trucks (pickups, vans). The fuel is contained in 200-bar steel cylinders (e.g. welding-gas cylinders). The technical, safety and energetic cost of gas compression, storage and filling is substantial enough to hinder large-scale application.



### **Converting diesel engines:**

Diesel engines are designed for continuous operation (10000 or more operating hours). Basically, they are well-suited for conversion to biogas utilization according to either of two methods:

In the **dual fuel approach** the diesel engine remains extensively unmodified, except for the addition of a gas/air mixing chamber on the air-intake manifold (the air filter can be used as a mixing chamber). The injected diesel fuel still ignites itself, while the amount injected is automatically reduced by the speed governor, depending on how much biogas is injected into the mixing chamber. The biogas supply is controlled by hand. The maximum biogas intake must be kept below the point at which the engine begins to stutter. If that happens, the governor gets too much biogas and has turned down the diesel intake to an extent that ignition is no longer steady. Normally, 15-20% diesel is sufficient. As much as 80% of the diesel fuel can thus be replaced by biogas. Any lower share of biogas can also be used, since the governor automatically compensates with more diesel.

As a rule, dual-fuel diesels perform just as well as comparable engines operating on pure diesel. As in normal diesel operation, the speed is controlled by an accelerator lever, and load control is normally effected by hand, i.e. by adjusting the biogas valve (keeping in mind the maximum acceptable biogas intake level). In case of frequent power changes at steady speed, the biogas intake should be somewhat reduced to let the governor decrease the diesel intake without transgressing the minimum diesel intake. Thus, the speed is kept constant, even in case of power fluctuations. Important: No diesel engine should be subjected to air-side control.

While special T-pieces or mixing chambers with a volume of 50 to 100% of the engine cylinder volume can serve as the diesel / biogas mixing chamber, a proper mixing chamber offers the advantage of more thorough mixing.

To sum up, conversion according to the dual-fuel method is:

- a quick & easy do-it-yourself technique;
- able to accommodate an unsteady supply of biogas;
- well-suited for steady operation, since a single manual adjustment will suffice and
- requires a minimum share of diesel to ensure ignition

**Conversion to Spark Ignition (Otto cycle)** involves the following permanent modifications at the engine:

- removing the fuel-injection pump and nozzle
- adding an ignition distributor and an ignition coil with power supply (battery or dynamo)
- installing spark plugs in place of the injection nozzles
- adding a gas mixing valve or carburetor
- adding a throttle control device
- reducing the compression ratio (ratio of the maximum to the minimum volume of the space enclosed by the piston) to  $E=11-12$
- observing the fact that, as a rule, engines with a pre-combustion or swirl chamber are not suitable for such conversion.

Converting a diesel engine to a biogas-fueled spark-ignition engine is expensive and complicated so that only pre-converted engines of that type should be procured.

### **Converting spark-ignition engines:**

Converting a spark-ignition engine for biogas fueling requires replacement of the gasoline carburetor with a mixing valve (pressure-controlled venturi type or with throttle). The spark-ignition principle is retained, but should be advanced as necessary to account for slower combustion (approx.  $5^{\circ}-10^{\circ}$  crankshaft angle) and to avoid overheating of the exhaust valve while precluding loss of energy due to still-combustible exhaust gases. The engine speed should be limited to 3000 rpm for the same reason. As in the case of diesel-engine

conversion, a simple mixing chamber should normally suffice for continuous operation at a steady speed. In addition, however, the mixing chamber should be equipped with a hand-operated air-side control valve for use in adjusting the air/fuel ratio (optimal "actual air volume/stoichiometric air volume" = 1.1).

Converting a spark-ignition engine results in a loss of performance amounting to as much as 30%. While partial compensation can be achieved by raising the compression ratio to  $\epsilon=11-12$ , such a measure also increases the mechanical and thermal load on the engine. Spark-ignition engines that are not explicitly marketed as suitable for running on gas or unleaded gasoline may suffer added wear & tear due to the absence of lead lubrication.

The speed control of converted spark-ignition engines is effected by way of a hand-operated throttle. Automatic speed control for different load conditions requires the addition of an electronic control device for the throttle.

The conversion of spark-ignition engines is evaluated as follows:

- Gasoline engines are readily available in the form of vehicle motors, but their useful life amounts to a mere 3000-4000 operating hours.
- The conversion effort essentially consists of adding a (well-turned) gas mixer.

# **Organic Fertilizer from Biogas Plants**

## **Organic substances in fertilizers**

While there are suitable inorganic substitutes for the nutrients nitrogen, potassium and phosphorous from organic fertilizer, there is no artificial substitute for other substances such as protein, cellulose, lignin, etc.. They all contribute to increasing a soil's permeability and hygroscopicity while preventing erosion and improving agricultural conditions in general. Organic substances also constitute the basis for the development of the microorganisms responsible for converting soil nutrients into a form that can be readily incorporated by plants.

## **Nutrients and soil organisms**

Due to the decomposition and breakdown of parts of its organic content, digested sludge provides fast-acting nutrients that easily enter into the soil solution, thus becoming immediately available to the plants. They simultaneously serve as primary nutrients for the development of soil organisms, e.g. the replenishment of microorganisms lost through exposure to air in the course of spreading the sludge over the fields. They also nourish actinomycetes (ray fungi) that act as organic digesting specialists in the digested sludge. (Preconditions: adequate aeration and moderate moisture).

## **Reduction of soil erosion**

The humic matter and humic acids present in the sludge contribute to a more rapid humification, which in turn helps reduce the rate of erosion (due to rain and dry scatter) while increasing the nutrient supply, hygroscopicity, etc. The humic content is especially important in low-humus tropical soils. The relatively high proportion of stable organic building blocks such as lignin and certain cellulose compounds contributes to an unusually high formation rate of stable humus (particularly in the presence of argillaceous matter). The amount of stable humus formed with digested sludge amounts to twice the amount that can be achieved with decayed dung. It has also been shown that earthworm activity is stimulated more by fertilizing with sludge than with barnyard dung.

Digested sludge decelerated the irreversible bonding of soil nutrients with the aid of its ion-exchanger contents in combination with the formation of organomineral compounds. At the same time, the buffering capacity of the soil increases, and temperature fluctuations are better compensated.

## **Reduction of nitrogen washout**

The elevated ammonium content of digested sludge helps reduce the rate of nitrogen washout as compared to fertilizers containing substantial amounts of more water-soluble nitrates and nitrites (dung, compost). Soil nitrogen in nitrate or nitrite form is also subject to higher denitrification losses than is ammonium, which first requires nitrification in order to assume a denitrifiable form. It takes longer for ammonium to seep into deeper soil strata, in part because it is more easily adsorbed by argillaceous bonds. However, some of the ammonium becomes fixed in a non-interchangeable form in the intermediate layers of clay minerals. All aspects considered, it is a proven fact, that ammonium constitutes the more valuable form of nitrogen for plant nutrition. Certainly, the N-efficiency of digested sludge may be regarded as comparable to that of chemical fertilizers.

In addition to supplying nutrients, sludge also improves soil quality by providing organic mass. The porosity, pore-size distribution and stability of soil aggregates are becoming increasingly important as standards of evaluation in soil-quality analyses.

## **Effects on crops**

Crop yields are generally acknowledged to be higher following fertilization with digested sludge. Most vegetable crops such as potatoes, radishes, carrots, cabbage, onions, garlic, etc., and many types of fruit (oranges, apples, guaves, mangos, etc.), sugar cane, rice and jute appear to react favorably to sludge fertilization.

In contrast, crops such as wheat, oilseed, cotton and baccra react less favorably. Sludge is a good fertilizer for pastures and meadows. The available data vary widely, because the fertilizing effect is not only plant-specific, but also dependent on the climate and type of soil. Information is still extensively lacking on the degree of reciprocity between soil fertility, type of soil and the effect of fertilizers (particularly N-fertilizers) in arid and semi-arid climates. Thus, no definitive information can be offered to date. Nor, for the same reason, is it possible to offer an economic comparison of the cost of chemical fertilizers vs. biogas sludge. The only undisputed fact that can be stated is that biogas sludge is better from an ecological point of view.



**Figure 15: Fertilisation with slurry: Transportation of slurry by a modified wheelbarrow and buckets**  
*Photo: Kellner (TBW)*

# The Contribution of Biogas Technology to Conservation and Development

## Conservation

The conversion of waste material into fertilizer and biogas helps protect the environment in five principal ways:

- The generated biogas can replace traditional energy sources like firewood and animal dung, thus contributing to combat deforestation and soil depletion.
- Biogas can contribute to replace fossil fuels, thus reducing the emission of greenhouse gases and other harmful emissions.
- By tapping biogas in a biogas plant and using it as a source of energy, harmful effects of methane on the biosphere are reduced.
- By keeping waste material and dung in a confined space, surface and groundwater contamination as well as toxic effects on human populations can be minimized.
- By conversion of waste material and dung into a more convenient and high-value fertilizer ('biogas slurry'), organic matter is more readily available for agricultural purposes, thus protecting soils from depletion and erosion.

## Development

Farmers, industrial estates, municipalities and governments have diverging concepts of development. They can use biogas technology in different ways to contribute to their own development objectives.

**Farmers** may want to substitute inputs such as fertilizers, household and engine fuels by biogas slurry and the biogas itself. A biogas system can relieve farmers from work that they have formerly spent on dung disposal or dung application on their fields. By using biogas for cooking, lighting and heating, life quality for the whole family can improve. Improved stables, if they are part of the biogas system, can increase the output of animal husbandry. Improved farmyard manure may raise the yields of plant production.

**Industrial estates** can, by processing their waste in a biogas plant, fulfill legal obligations of waste disposal. They can, at the same time, generate energy for production processes, lighting or heating.

**Municipalities** can use biogas technology to solve problems in public waste disposal and waste water treatment. The energy output of biogas digestion is usually not a priority, but may respond to public energy demands such as street lighting, water pumping and cooking in hospitals or schools.

**National Governments** have macro-economic interests that may render biogas technology an interesting option in overall development plans. On a national scale, a substantial number of working biogas systems will help reduce deforestation, increase agricultural production, raise employment, and substitute imports of fossil fuels and fertilizers. If macro-economic benefits are obvious and quantifiable, a government may even consider to subsidize biogas systems to bridge a micro-economic profitability gap.

**Craftsmen, engineers and maintenance workers** have long been overlooked as a target group for biogas promotion. Not only does biogas technology open market niches for masons, plumbers, civil engineers and agronomists, they are often the most effective promoters of biogas technology.

## Under which conditions can biogas technology contribute to development and conservation?

**Mature technology:** A positive contribution of biogas technology can only materialize, if the technology works. The development of biogas technology has passed the experimental stage. Trials with uncertain outcome can only be accepted if the costs of failure are not to be paid by the end-users. Whatever the chosen design of the biogas plant may be, those in

charge for its dissemination bear the responsibility to deliver a reliable, durable and user-friendly product.

**Appropriate Design:** Only appropriate designs will perform satisfactory and will have a favorable cost-benefit ratio. Existing basic designs of biogas systems have to be adapted to the following framework conditions:

- climatic and soil conditions;
- the quality of substrate to be digested;
- the quantities of substrate;
- the prioritization of expected benefits;
- the capital available;
- the availability of skills for operation, maintenance and repair.

**Official Policy Support:** The policies of governments and donor organizations cannot turn immature technologies and inappropriate designs into success stories, nor can they create an artificial demand for alternative energy or improved fertilizer. But where a national need for energy alternatives exists and the increasing burden of water pollution, deforestation and soil depletion is felt, governments can support biogas dissemination by a legal framework against unsustainable use of natural resources and in favor of green technologies.

Donor organizations can provide take-off funding and initial technical assistance where biogas technology is hitherto unknown.

**The 'Critical Mass' of Biogas Systems:** For small and medium scale farmers, the investment in a biogas system is a considerable risk. Besides the confidence in the technology itself, they need reassurance from neighbors and colleagues. Farmers believe what they see. The more working biogas systems are around, the more they will be willing to invest. In addition, professional (commercial) advice, maintenance and repair will only evolve, if a sufficient number - the 'critical mass' - of biogas systems are established in the area.

## **Limitations of Biogas Technology**

Currently, there is no doubt anymore that biogas systems all over the world are functioning under a variety of climatic conditions. They respond successfully to needs of poor rural populations, urban communities and industrial estates. However, a widespread acceptance and dissemination of biogas technology has not yet materialized in many countries. One main reason, often mentioned, is the required high investment capital. But often the reasons for failure were the unrealistically high expectations of potential users. Biogas technology cannot solve every problem of a farm, a village or a big animal production unit. If disappointment is to be avoided, the limitations of biogas technology should be clearly spelt out. If from the below listed guiding questions one or more cannot be answered with 'YES', the success of biogas technology is questionable or even unlikely.

### **Is there a real problem that biogas technology can address?**

e.g. Is there a problem with the affordability and availability of energy?

Is the substrate to be bio-degraded an environmental hazard?

Is the lack of high-quality fertilizer a serious problem in the farming system?

### **Can a permanent supply of bio-degradable material be guaranteed at low cost?**

e.g. Are animals kept in a stable, connected to the biogas plant?

Would filling the biogas plant reduce the workload of the farmer?

If necessary, is transport capacity for the substrate guaranteed permanently?

Will the biogas plant be connected reliably to the sewage system?

### **Can the financing of biogas systems realistically be solved?**

e.g. Do potential users have access to credit?

Can a substantial subsidy be expected from private or public sources?

How realistic is the optimism of the biogas plant owner-to-be?

### **For unheated biogas plants: does the climate allow bio-digestion for most of the year?**

**Under arid conditions: Is the availability of water secured and affordable?**

**Is the use of human feces as substrate and fertilizer culturally acceptable?**

**Is the use of biogas, generated from human waste, acceptable for cooking?**

**Are there allies among government and institutional decision makers with a certain degree of awareness of environmental problems?**

**Is in the region a sufficient number of skillful craftsmen available who can be upgraded to be 'biogas technicians'?**

e.g. Is good quality masonry work known in the region?

Is plumbing a trade that is practiced in the region?

### **Does the number of potential biogas users in the region justify a 'biogas project' or the establishment of private 'biogas business'?**

Biogas technology is not a universally accepted technology such as the transistor radio. A biogas plant has to fit into existing farming-, production- or waste disposal systems. Attempts to make the system fit to the biogas plant will result in expensive and frustrating failures.

Biogas technology has many competitors. Energy can be produced by fuelwood plantations (with other positive side-effects), by solar systems, micro-hydro-power and other renewable

energy technologies. Producing high quality fertilizer can be done in other, cheaper ways such as composting which are even closer to traditional techniques.

What makes biogas an attractive option is the fact that this technology can provide solutions to a variety of problems simultaneously. That is, if this variety of problems exists.



## **Biogas - Framework Conditions**

The implementation of biogas projects and programs, even on a small-scale level, must take into account the underlying socio-cultural, political, economic and ecological conditions. As an appropriate technology, mainly for rural areas, the realization of economically viable and sociologically and ecologically beneficial biogas projects heavily relies on social and political acceptance. Benefits of biogas as well as major obstacles depend on the specific and complex relationships between social organization, economic premises, environmental problems and political intentions.

### **Social aspects in the planning process**

Participation of the local population is a key issue in the project planning phase. People should be involved as early as possible. The basic facts about biogas technology should be made clear beforehand, so that possible problems of biogas technology are transparent to the actors involved. Obstacles can arise from religious and/or social taboos in the following respects:

- prohibitions in the use of gas primarily for the preparation of food
- prohibitions in the use of the slurry
- social prohibition of work involved in running a biogas unit, either due to the separation of classes, sexes, age groups or due to ethnic or religious affiliation.

In order to deal with these obstacles in a way that considers local conditions as well as requirements of the project, the assistance and attitude of ruling or generally recognized institutions is of major importance. Class structure and barriers have to be taken into account for as well. General features of the society's class structure and comparison with neighboring areas and/or similar projects can serve for a preliminary analysis. The concrete conditions in the project area have to be investigated based on this "general model" focusing on the social position of the target group. For the delegation and organization of tasks during the project, the existing social regulations on the division of labour represent a framework, that is often difficult to determine. Women are often kept out of decision-making processes even though they are usually the primarily affected group regarding household energy issues. Their participation can, for instance, be encouraged by integration into authoritative bodies or by forming special female committees.

### **Social and political aspects in the dissemination process**

For the dissemination of biogas technology certain social and cultural convictions and norms can act as impediments:

- Ethical barriers
- Sociocultural taboos
- Defense mechanisms, (specifically against the use of human excrements as fertilizer)
- Lack of regularity in the attendance and maintenance of biogas systems
- Fertilization

The implementation of biogas programmes is also linked to a number of political and administrative factors that have to be considered.

### **Specific regional developments**

Specific developments in the region can, positively or negatively, impact a biogas dissemination program. They can occur, for example, as the result of:

- *Regional (energy) development:* a dam is built in a region and the population is resettled. In many aspects the resettlement villages would be ideally suited for community biogas plants. The villages are to be newly constructed and can be designed accordingly. Moreover, social mobility is increased by resettlement. On the other hand the dam is being erected to produce electricity. Biogas will have to compete with (possibly cheap) electric energy.

- *Emergencies:* a village has had to be resettled because of a natural disaster. Similar planning advantages apply as in the first example. Care must be taken here to ensure that biogas is not misunderstood as an "emergency measure" but as a development initiative arising out of an emergency situation.
- *Changes in infrastructure:* an all weather road is to be constructed to link a previously remote area to the urban center. This will change the prices for building materials, for charcoal and labor. The cost-efficiency of biogas plants may increase as a result.
- *Conservation policies:* the area in question will soon be part of a large national park. The collection of firewood will be largely restricted, the road infrastructure improved and access to development funds made easier.
- *Other technology innovations* in the area which have led to disruptions within the social structure, or which have evoked the fear of disruptions. The result can be a negative attitude towards technological innovation.

## **National energy & fertilizer supply strategies**

### **Chemical fertilizer**

For developing countries, the production of biogas and bio-fertilizer holds the promise of substituting increasing amounts of imported fossil fuels and mineral fertilizers. On an economic scale, the importance of digested sludge as a supplementary source of fertilizer is gradually gaining recognition. As populations continue to grow, there is a corresponding increase in the demand for food, fertilizers and energy. Consequently, for example in India, both the production and consumption of chemical fertilizers have been steadily expanding over the past decades.

According to a recent estimate by Indian experts, the national consumption of mineral fertilizers could be reduced by 30-35% through the use of digested biogas sludge as fertilizer.

### **Fertilizer policies, energy policies**

For biogas programs, it is crucial,

- to be familiar with official government policies on fertilizers and fuel;
- to be familiar with the realities of implementation of these policies;
- to have a clear understanding of the possibilities and processes of policy change. This includes an intimate knowledge of persons and institutions involved in possible policy changes.

If national policies have a strong self-reliance character, involving high import taxation on mineral fertilizers and fossil fuel, biogas technology will have an easy start. If world market integration is high on the agenda of national planning, biogas technology will face stiff competition from imported fuels and fertilizers.

According to available economic data, it may be assumed that (at least in remote, sparsely settled areas) biogas programs are usually less costly than comparable energy & fertilizer supply strategies based on fossil resources, like electrification and the production or importation of chemical fertilizers. The latter strategies involve not only high transmission and transportation costs, but are also largely dependent on imports.

In any comparison between biogas technology and traditional approaches to the provision of energy and fertilizer, due consideration should be given to the fact that the continuation or expansion of the latter would surely magnify the ecological damage that has already been done and accelerate the depletion of natural resources.

### **Environmental aspects**

Biogas technology is feasible in principle in most climatic zones under all climatic conditions, where temperature or precipitation are not too low.

Using biogas technology is, besides direct thermal or photovoltaic use and hydropower, a form of using solar energy, mediated through the processes of photosynthesis (for build-up of organic material) and anaerobic decomposition. As such it is a renewable energy source. In many regions of the world, the consumption of firewood exceeds natural regrowth. This leads to deforestation and degradation of forests and woodlands with adverse effects on climate, water budget, soil fertility and natural products supply. Biogas is one of the solutions to this problem, because it substitutes firewood as a fuel and helps sustaining favourable soil conditions. It is also an important contribution to the mitigation of the global greenhouse effect.

The potential contribution of biogas technology to combat deforestation, soil erosion, water pollution and climate change is undisputed. But how much support biogas dissemination will receive from government institutions will depend largely on the role of environmental considerations in government decision making.

The success of biogas technology also depends on the influence of potential allies in the environmental NGO scene. Biogas programs can, if environmental policies are favorable, be perceived as "status projects" for environmental authorities.

# Socio-Cultural Aspects of Biogas Projects

## Participation

The basic principle of any planning should be to involve those concerned in the planning process as early as possible. This principle applies even more if the pre-feasibility studies have revealed a considerable amount of problems. In any case it is better to discuss these quite openly with those concerned and seek mutual solutions rather than to rely on the method "it will all work out in the end".

The point in time when participation is started is decisive. It is too early to expect full participation before the technology has reached a certain technical maturity and the conditions for its dissemination are fully explored. It is, on the other hand, just as wrong to confront people with 'final solutions'. In this case there is the risk of obtaining verbal agreement without effective consequence. The ideal time for introducing concept and technology is during the last phase of the investigation, when preliminary results can be shown to those concerned as a basis for discussion. These discussions serve as a first test of the preliminary results. Furthermore, the structures of leadership and decision making can be observed clearly in such situations.

That does not mean that each of the proposals by the community should be accepted blindly. The fact that biogas technology requires a specific technical and economical organization should be stressed. A breakdown of planning would be preferable to unfeasible compromises. In view of this it is often advisable to invite the local technician to take part in these negotiations. His technically based arguments tend to be well accepted in situations of disagreement.

## Religious and social taboos

Taboos, as a rule, are always of an overall social character. Violation of taboos is sanctioned (penalized), the extent and form of penalty being determined socially. Sanctions can vary from a direct 'punishment' to social disrespect. In many cases an immediate punishment (corporal punishment, exile from the village etc.) is no longer possible nowadays as state legislation claims a monopoly for punishment. This does not simplify the problem but makes it even more difficult. Instead of an official, foreseeable punishment, social exclusion occurs now in many cases and can be just as serious for those concerned but becomes practically inaccessible for a project or for authorities. As 'social punishment' is forbidden the 'sanctions' are not spoken about, especially when they target a program desired and aided by the state. An exclusion of participants by the community with all its negative consequences is not declared as such by the community and therefore rarely directly accessible.

On the other hand, from these 'sanctions' arises the opportunity to overcome resentments. In general, sanctions are governed by a 'ruling instance' or 'authority' who watches over these taboos and proclaims the punishment when they are violated. But this authority also determines possible exceptions. A general misconception is that taboos basically 'cannot be broken'. No society is inflexible to the extent that regulations do not allow for changes and modifications. In any case, exceptions have to be agreed upon by a recognized instance.

## Authorities

Authorities can be:

- **for religious taboos:** priests or members with a religious function, for instance the elders of the community.
- **for social taboos:** social leaders, e.g. the elders, traditionally or modern politically leading groups or personalities etc. Often older women play a more important role than the outside observer would see.
- **or general:** especially recognized members (key persons), either in the sense of traditional structures of leadership or people of certain professions like teachers or local bank managers.

## **Disregard of taboos**

For the acceptance of exceptions a person or group of persons has a greater effect the more the taboo and the system behind it is generally recognized. If the system and its leaders have been accepted they become the only instance to be consulted concerning exceptions. Any opposition to this group will result in resistance even if individuals within the group are prepared to disregard the regulations.

It should not be assumed that any recognized leader can disregard taboos or suspend them and remain unpunished. These people are also part of the system and have to observe the rules of the system. It is quite right to start lobbying for technical innovations with recognized leaders, but is also necessary, if they can be won, to leave them with the initiative and allow them to decide on the procedure of technology introduction.

Just as the general extensive survey provides the basis for the problem analysis and the starting point of a project, it is essential to recognize that local application cannot be structured according to a general method but has to be integrated in the local context. To mention one example, priests are generally seen as religious leaders but this does not mean that their influence is equal in all localities. Cooperation with priests for local programs should depend on the quality of their local status.

## **Social classes and class barriers**

In their general features, social classes are the binding structure in each society and an important phenomenon which has to be reckoned with and included early enough in planning. It must be taken into account that class structures and class barriers exist in locally specific variations which have a considerable influence on implementation. Typical deviations are:

### **a) *For hierarchical societies:***

- the absence of certain hierarchical groups in a village
- the shifting of the hierarchy on account of certain (changing) conditions
- a restructuring of the hierarchy for certain projects

### **b) *For more egalitarian societies:***

- the abolition of egalitarian principles by specific village personalities
- the abolition of egalitarian principles by specialization

As these deviations cannot be foreseen, it is wise to compare the results of similar or comparable projects for the preliminary analysis. An essential preliminary analysis offers the following possibilities:

- the development of a general class model including test criteria to check its local application
- the potential for the allocation of individual functions
- the potential for the allocation of certain jobs

## **Development of a general model**

If such a quite rudimentary model is enriched by additional material from other measures in neighboring areas, a series of check questions can be derived and applied in the target area or group. This preliminary model serves as a reference instrument for the main survey and also as a control for results gained. The latter is very important since over-optimistic statements can be made by target groups which are interested in project measures. This applies to the whole project as well as to the allocation of special functions to individual groups. The model is in no case a substitute for a local survey. Local deviations, possibly on account of personality, can be so great that they do not principally change the model but can very much affect the degree of functioning in an initial implementation.

## **Definition of position of the target group**

Equally important to the development of question and control structures is the definition of position of the target group in relation to neighboring groups. The extensive observation of

the whole society can provide a series of criteria for the initial analysis. Special importance is attached to this method in the following situations:

a) The proposed group or institution is not or only minimally self-sufficient in its biogas measures. It requires deliveries (material or service) from other groups, either a neighboring village or another enterprise.

Such matters become relevant whenever certain regulations exist within the extensive class system but do not appear within the local system. In such cases an investigation has to take place, for example, whether neighboring groups who would have to deliver substrate, would accept this.

This investigation is of great importance when within the target group a 'violation' of the class system is accepted. It is frequently found out afterwards that this 'violation' is not given because the essential suppliers do not accept their counterparts; now and again it can be seen that certain groups within the target group only give their approval because they are sure that the conditions negotiated would not be accepted by the partner groups.

b) The implementation takes place within the context of a more extensive program, possibly a pilot program. In this case it is not sufficient to obtain the acceptance only within the temporary target group but an investigation into whether this model is acceptable for later target groups has to be carried out.

Although it is in principle practicable to keep the model variable for later adaptation to other target groups, it should not be overlooked that the interest of later target groups will be affected by the pilot model. 'Violations' against social norms which are acceptable for the initial target group could be rejected in neighboring communities and lead to a general rejection of the 'biogas project'. Consequently pilot models should avoid 'far-reaching' violations even if these are locally possible.

## **Social regulations for the division of labor**

### **Reasons for regulations on the division of labor**

Social regulations for the division of labor can arise for the following reasons:

- Privileges of certain groups in taking over specific jobs or being released from less desirable work. These privileges can stem from belonging to a social or ethnic group, age group or sex.
- Social and traditional allocation of specific work for specific groups. The division of labor among the sexes belongs here.
- 'Regulations' on the division of labor caused by political or economic dependency which means e.g. the necessity for the 'village rich' to carry out certain tasks in order to secure labor during agricultural seasons etc.

The regulations on the division of labor always prove to be an especially persistent phenomenon; 'leading' groupings frequently refuse to carry out socially or religiously 'banned' jobs (handling feces, heavy manual work etc.) as they are 'non-rank conform' and force socially or economically dependent groups to take over these tasks. This applies especially to the division of labor between sexes.

### **Difficulties in researching social regulations**

To investigate in social regulations is difficult as their existence is often not admitted to 'strangers', however strong their influence on the later course of the measures may be. It is not an exception when, for example, in an interview a man agrees to take over a certain task - but means in saying this that his wife or a person dependent on him will carry out the task. For the interviewee this is no 'lie'; for him it is a matter of course that he means, by agreeing, that he will allocate the task. In individual interviews this leads to wrong interpretations which

could have a considerable influence on the implementation model. Leaders in many societies assume that their statement will be valued as correct. Who would think that they carry out such jobs themselves? On the other hand, the purpose of the interview is accurately guessed and the answer given accordingly. The implementer would like an as even distribution of work as possible; he could consider the regulations of labor division to be 'bad'. And so, the answer is given accordingly, so that no one has to be 'ashamed'. Unfortunately this changes nothing as far as the later reality is concerned. Especially in the case of traditionally underprivileged groups, often including women, it has to be expected that the 'leaders' as well as the 'laborers' find it very difficult to give correct statements on the division of tasks.

## **Conclusions**

It can be concluded that:

- On the one hand an extensive preliminary investigation which can often refer to literature is essential. If there are general strong tendencies towards division of labor within a target region, statements concerning the even delegation of jobs within the target group have to be treated with caution.
- The local interviewing of the target group does not initially refer to the future project, but to comparable, existent job routines. If there is a strict division of labor here, no promises of an egalitarian division of work within the proposed biogas project should be made.

## **Gender considerations**

Women are kept out of many decision-making processes as far as they exceed the family, are connected with the allocation of finances or are concerned with 'technical measures'. On the other hand, women may be the main interested parties concerning biogas for cooking. Once a plant is constructed, they are the most affected by the malfunctioning of a plant.

## **Forms of participation**

Which form of participation is appropriate for women cannot be decided from outside. It is of little use to the women if they are 'forced' into a decision-making body without being truly accepted by other members. Their impact could be even less than by influencing of the husband. When there are problems with the plant, it is the women who can be a stabilizing element. As they are more affected by malfunctioning of the plant, they are more interested than men in, for example, a well functioning repair service.

Different models should be considered according to the standing of women in society:

- the careful integration of women into decision making bodies
- women committees for the regulation of consumer problems whilst matters of finance are left to the men
- specialized committees with a mixed central body

## **Special female committees**

The impact of a female committee should not be underestimated. Even if it has no direct influence on decisions it embodies a greater confidence of the women and so indirectly influences decisions. This sort of special committee can also be an initial step towards full participation in the future.

It is necessary to take not only the women but also the men into consideration when discussing gender specific questions. A participation model which is not effective for these will also not help the women.

# **Social Problems Affecting the Propagation of Biogas Technology**

## **Ethical barriers**

Many religions have very strict laws with regard to cleanliness, especially in connection with human and, to a lesser extent, animal excrement. The suppression or bypassing of such laws is always a mistake. Every new case of illness would invariably be ascribed to the transgression of religious laws. It would be of little importance how much such an illness may actually have to do with the production of biogas.

Implementation strategies should be based on cooperation with appropriate domestic institutions that are looked upon as benign and "clean". The positions and attitudes of such institutions must always be clarified in advance, since it is not their general posture that is of decisive importance, but rather their attitudes with respect to the transgression of religious doctrine. For example: the socio-cultural expectation is that illness will result from the handling of human or animal excrement. Since, however, hospitals are generally accepted as the absolute "experts" in matters of health (or lack of it), it could have a beneficial model effect on the popularization of biogas technology to see that their local hospital or dispensary is operating a biogas system.

On the other hand, hospitals are also regarded as secular institutions; one accepts their services as a 'necessary evil' without affording them a social rank. Seen in that light, religious taboos cannot be overcome by way of the hospital's example. At best, the reaction would amount to: "They can get away with it. They have special defense powers. But we don't!".

## **Socio-cultural taboos**

Many socio-cultural taboos, though rooted in ancient religious beliefs, have gradually become altered by way of missionary activities and the extenuation of religious interests to "generally applicable" taboos, which are frequently more difficult to handle than "pure" religious taboos, since no priest or minister is able to exert any influence. The only way to overcome taboos is by way of example. Highly respected members of the community, approved educational institutions, etc. may be able to make inroads in a model function. Here, too, a preliminary study of the envisioned mediator is imperative. The question of individual acceptance must be clarified in advance. It is by no means a foregone conclusion that someone who is considered highly acceptable in a certain field or function, e.g. politics, will enjoy the same high standing in a different context, e.g. hygiene.

Of equal importance is the effective investigation of existing interrelations between, and relative influence of, the various taboos. For example, the socio-cultural cross-linkage between social behavior and illness must be expected to appear illogical to a Western implementer. Such associations must be heeded if the strategy being applied is to meet with success in generating acceptance for biogas and in instigating a (partial) breach of taboos. Often enough, the breakthrough may be easier to achieve indirectly (by way of the cross-links) than directly. In the Pacific region, for example, human feces were traditionally "disposed of" by pigs. This was a matter of general practice and no one considered it repulsive. The potential solution: a "three-in-one" system in which the human excrement "pass through" the pigs, so to speak, by being routed underneath the pigpen on their way to the digester. No one "sees" what actually takes place, or more precisely, what does not take place.

## **Defense mechanisms against the use of human excrements as fertilizer**

In practical terms, this subject could be viewed as a subgroup of the socio-cultural taboos, the main distinction being that the use of night-soil for the production of biogas is regarded as acceptable, but the use of the digested sludge as fertilizer is not. This stance is particularly well-entrenched in regions where the use of fertilizers is relatively new, and mineral fertilizers have been introduced as a "clean" product, i.e. in regions where shifting cultivation is traditional.



It is unusual in such regions to find that the arguments against the use of manure have been generated, or at least amplified, by hygiene propaganda. In the Pacific Basin, for example, a region in which few epidemics have been known so far, but were belatedly infused by way of acculturation. A potential solution would be to conduct demonstrations in cooperation with institutions known for - and viewed as credible because of - their close involvement with matters of hygiene.

### **Irregular attendance and maintenance of biogas systems**

This is a frequent problem in the tropics, where the climate dictates no particular sequence of agricultural activities. Applied to biogas systems, the connection between a process breakdown and irregular charging is not immediately recognizable, because there is a substantial time lag between the owner's forgetting to feed substrate into the system and the eventual, resultant decrease in gas production. Similarly, once the biogas system has stopped producing, it will take up to about 10 days of regular charging to get the gas production back to normal levels. Once again, the connection is blurred. The only possible solution would be to provide long-term intensive training aimed at instilling an appreciation for the need to ensure that the system is charged on a regular basis.

### **Fertilization**

This problem stands in close relation to the ethical barriers, socio-cultural taboos, defense mechanisms and the lack of regularity in the attendance of biogas systems. Insufficient, untimely or otherwise improper fertilizing may be the result of a lack of familiarization with regard to the work involved, the type of fertilizer being used or the necessity of methodical regularity. To the extent that neither ethical barriers nor socio-cultural taboos are involved, the only workable approach is to provide intensive training for the owner-operators.



**Figure 16: Toilet (under construction), directly connected to the plant**  
*Photo: Kellner (TBW)*

# Political and Administrative Frame Conditions for Biogas Programmes

## Political will and public opinion

The development of biogas technology depends on the political will of donor and recipient governments. It is the task of the governmental and administrative authorities to provide access to the technology and to secure and organize the requisite material, financial and legal basis. According to their political will to promote biogas, governments can play a more or less supportive role in biogas research, information dissemination and regulations for funding, subsidies or tax waving. The formation of a political will does not evolve in a vacuum. Political will and public opinion develop in interrelation. Successful practical examples, encouraging research findings, the use of media to spread information, all these are tools to influence both political will and public opinion.

Biogas programs should attempt to lobby for biogas at various entry points of the government system simultaneously. Creating a favorable climate for biogas dissemination depends almost always on a whole range of decision makers. For example:

- *The Ministry of Finance* will decide on subsidies and tax wavers for biogas users.
- *The Ministry of Energy* can propose laws regarding the feeding of biogas-produced electricity into the grid. It can also propose financial and other assistance.
- *The Ministry of Agriculture and Livestock* can include biogas in the training curriculum of extension officers and agricultural colleges.
- *The Ministry of Education* can include biogas in the curricula of high schools and promote the construction of bio-latrines for schools.
- *The Ministry of Health* can include biogas in the curricula of public health workers and encourage the building of bio-latrines for hospitals.

Simultaneously to political lobbying, PR work is important to influence public opinion:

- *Radio Programs* are an effective means in rural areas to familiarize the population with basics of biogas technology.
- *Articles in Print Media* usually reach members of the middle class, among whom are the most promising potential users: middle to large farmers.
- *Pilot Biogas Systems* must be located strategically to be easily accessible. The more these pilot plants have a 'real life character', i.e. be an operational part of a farm, the more convincing they will be for other farmers.
- *Visits in Agricultural Schools and Colleges* does not reach the decision makers of today, but lays the ground for biogas acceptance in the future.



**Figure 17: Sign of the National Biogas Department/National Energy Board in Ghana**  
*Photo: Kellner (TBW)*

## **Program goals**

Since the actual installation of a biogas plant is ultimately the decision of the individual investor, it is important that the program goals and the organizational environment is conducive to affirmative individual decisions. The prerequisites for this must be established at all planning stages by and for all sectors concerned. A biogas program which is part of a larger development program must harmonize with the other departments of the parent program. The introduction of biogas as an alternative source of energy affects various sectors, each of which functions within its own specific structural setting. These, of course, vary from one country to another. As a rule, the responsibilities within a biogas program should be distributed along the lines of existing contacts with the corresponding target groups. If, for example, certain farmers are considered the target group of an information campaign, it would be appropriate to have the ministry of agriculture be involved in the biogas program.

## **Administration**

No new administrative bodies should be established for performing the above tasks. Instead, it is advisable to set up biogas promotion units or biogas contact persons within the existing departments and agencies. Within the framework of a well-established development program, particular importance should be attached to self-help groups, voluntary agencies and/or private foundations.

The authorities' efforts in favor of biogas promotion will be more effective, if sufficient detailed information is placed in the hands of the self-help groups. The concerned administrative bodies must disseminate the requisite information and provide inexperienced groups with a satisfactory explanation of how to best exploit the promotional options available to them. Practical assistance should be offered wherever possible. Active self-help groups will then become ideal multipliers.

# Environmental Frame Conditions of Biogas Technology

## Climatic conditions for biogas dissemination

### Temperatures

Biogas technology is feasible in principle under almost all climatic conditions. As a rule, however, it can be stated that costs increase for biogas production with sinking temperatures. Either a heating system has to be installed, or a larger digester has to be built to increase the retention time. Unheated and un-insulated plants do not work satisfactory when the mean temperature is below 15 °C. Heating systems and insulation can provide optimal digestion temperatures even in cold climates and during winter, but the investment costs and the gas consumption for heating may render the biogas system not viable economically.

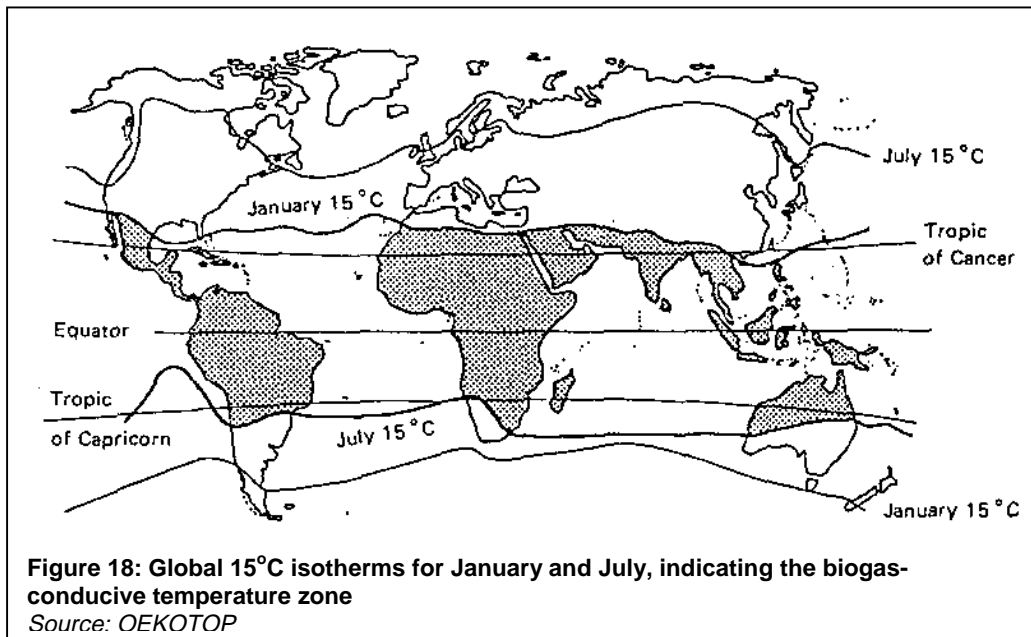

Not only the mean temperature is important, also temperature changes affect the performance of a biogas plant adversely. This refers to day/night changes and seasonal variations. For household plants in rural areas, the planner should ensure that the gas production is sufficient even during the most unfavorable season of the year. Within limits, low temperatures can be compensated with a longer retention time, i.e. a larger digester. Changes of temperature during the course of the day are rarely a problem as most simple biogas digesters are built underground.

### Precipitation

The amount of seasonal and annual rainfall has mainly an indirect impact on anaerobic fermentation:

- Low rainfall or seasonal water scarcity may lead to insufficient mixture of the substrate with water. The negative flow characteristics of substrate can hamper digestion.
- Low precipitation generally leads to less intensive systems of animal husbandry. Less dung is available in central locations.
- High precipitation can lead to high groundwater levels, causing problems in construction and operation of biogas plants.

## Suitability of climatic zones

**Tropical Rain Forest:** annual rainfall above 1.500 mm, mean temperatures between 24 and 28°C with little seasonal variation. Climatically very suitable for biogas production. Often animal husbandry is hampered by diseases like trypanosomiasis, leading to the virtual absence of substrate.

**Tropical Highlands:** rainfall between 1.000 and 2.000 mm, mean temperatures between 18 and 25°C (according to elevation). Climatically suitable, often agricultural systems highly suitable for biogas production (mixed farming, zero-grazing).

**Wet Savanna:** rainfall between 800 and 1.500 mm, moderate seasonal changes in temperature. Mixed farming with night stables and day grazing favor biogas dissemination.

**Dry Savanna:** Seasonal water scarcity, seasonal changes in temperatures. Pastoral systems of animal husbandry, therefore little availability of dung. Use of biogas possible near permanent water sources or on irrigated, integrated farms.

**Thornbush Steppe and Desert:** Permanent scarcity of water. Considerable seasonal variations in temperature. Extremely mobile forms of animal keeping (nomadism). Unsuitable for biogas dissemination.

## Firewood consumption and soil erosion

A unique feature of biogas technology is that it simultaneously reduces the need for firewood and improves soil fertilization, thus substantially reducing the threat of soil erosion. Firewood consumption in rural households is one of the major factors contributing to deforestation in developing countries. Most firewood is not acquired by actually cutting down trees, but rather by cutting off individual branches, so that the tree need not necessarily suffers permanent damage. Nonetheless, large amounts of firewood are also obtained by way of illegal felling.

In years past, the consumption of firewood has steadily increased and will continue to do so as the population expands - unless adequate alternative sources of energy are developed. In many developing countries such as India, the gathering of firewood is, strictly speaking, a form of wasteful exploitation. Rapid deforestation due to increasing wood consumption contributes heavily to the acceleration of soil erosion. This goes hand in hand with overgrazing which can cause irreparable damage to soils. In the future, investments aimed at soil preservation must be afforded a much higher priority than in the past. It will be particularly necessary to enforce extensive reforestation.

## Soil protection and reforestation

The widespread production and utilization of biogas is expected to make a substantial contribution to soil protection and amelioration. First, biogas could increasingly replace firewood as a source of energy. Second, biogas systems yield more and better fertilizer. As a result, more fodder becomes available for domestic animals. This, in turn, can lessen the danger of soil erosion attributable to overgrazing. According to the ICAR paper (report issued by the Indian Council of Agricultural Research, New Delhi), a single biogas system with a volume of 100 cft (2,8 m<sup>3</sup>) can save as much as 0.3 acres (0,12 ha) woodland each year.

Taking India as an example, and assuming a biogas production rate of 0.36 m<sup>3</sup>/day per livestock unit, some 300 million head of cattle would be required to produce enough biogas to cover the present consumption of firewood. This figure is somewhat in excess of the present cattle stock. If, however, only the amount of firewood normally obtained by way of deforestation (25.2 million trees per year) were to be replaced by biogas, the dung requirement could be satisfied by 55 million cattle. Firewood consumption could be reduced to such an extent that - at least under the prevailing conditions - a gradual regeneration of India's forests would be possible.

According to empirical data gathered in India, the consumption of firewood in rural households equipped with a biogas system is much lower than before, but has not been fully eradicated. This is chiefly attributable to a number of technical and operational shortcomings. At present,

- many biogas systems are too small to handle the available supply of substrate;

- many biogas units are operated inefficiently;
- many of the existing biogas systems are not used due to minor mistakes;
- biogas users tend to increase energy consumption to the point of wastage, then requiring additional energy in the form of firewood.

A more serious problem, however, is the fact that a household biogas system program can only reach the small percentage of farmers who have the investment capital required. The majority of rural households will continue to use firewood, dried cow dung and harvest residues as fuel.

### **Reduction of the greenhouse effect**

Last but not least, biogas technology takes part in the global struggle against the greenhouse effect. It reduces the release of CO<sub>2</sub> from burning fossil fuels in two ways. First, biogas is a direct substitute for gas or coal for cooking, heating, electricity generation and lighting. Additionally, the reduction in the consumption of artificial fertilizer avoids carbon dioxide emissions that would otherwise come from the fertilizer producing industries. By helping to counter deforestation and degradation caused by overusing ecosystems as sources of firewood and by melioration of soil conditions biogas technology reduces CO<sub>2</sub> releases from these processes and sustains the capability of forests and woodlands to act as a carbon sink.

Methane, the main component of biogas is itself a greenhouse gas with a much higher "greenhouse potential" than CO<sub>2</sub>. Converting methane to carbon dioxide through combustion is another contribution of biogas technology to the mitigation of global warming. However, this holds true only for the case, that the material used for biogas generation would otherwise undergo anaerobic decomposition releasing methane to the atmosphere. Methane leaking from biogas plants without being burned contributes to the greenhouse effect! Of course, burning biogas also releases CO<sub>2</sub>. But this, similar to the *sustainable* use of firewood, does only return carbon dioxide which has been assimilated from the atmosphere by growing plants maybe one year before. There is no net intake of carbon dioxide in the atmosphere from biogas burning as it is the case when burning fossil fuels.